

MSD INSTALLATION INSTRUCTIONS

Atomic EFI Throttle Body PN 2905

ONLINE PRODUCT REGISTRATION: Register your MSD product online. Registering your product will help if there is ever a warranty issue with your product and helps the MSD R&D team create new products that you ask for! Go to www.msperformance.com/registration.

Thank you for purchasing the MSD Atomic EFI Throttle Body. The throttle body features integrated fuel rails, injectors, ECU, and sensors to minimize the difficulties associated with converting carbureted fuel systems over to Electronic Fuel Injection. Since the Atomic Throttle Body uses a standard 4 bolt pattern used by most carburetors on the market today, the Atomic Throttle Body is a true bolt on design.

Parts Included:

1-Atomic EFI Throttle Body
1-Intake Manifold Gasket
1-Air Cleaner Gasket

Parts needed but not included:

4 – Retaining Stud Kit for the throttle body
Fuel system: Fuel pump, fuel filter, fuel line, fuel pressure regulator (return system)
Atomic EFI Power Module
Atomic EFI Handheld Programmer
Throttle linkage connection/brackets
Ignition system

The Atomic Throttle Body has a 4160 bolt pattern and will fit most 4 barrel manifolds. It is designed to accept common throttle linkage adapters and brackets. A throttle ball stud is supplied but no other linkage components are included. Accessory kits are available through many accessory or carburetor companies. There are two fuel inlets, a forward and rear fuel inlet. Only one needs to be connected on a PWM style system as fuel is delivered to either side through an internal fuel rail. On a return style system, an additional -6AN O-ring fitting will be required to run the fuel through the other rail into the fuel pressure regulator. The passenger side of throttle body, where the MSD is machined, is the Electronic Control Unit (ECU). This block houses the ECU of the Atomic Throttle Body.

FUEL SYSTEM

The Atomic EFI Throttle body will work with a returnless (Figure 1) and return (Figure 2) style fuel system.

Note: Do not use tubing (hard fuel lines) with the Atomic EFI return-less system.

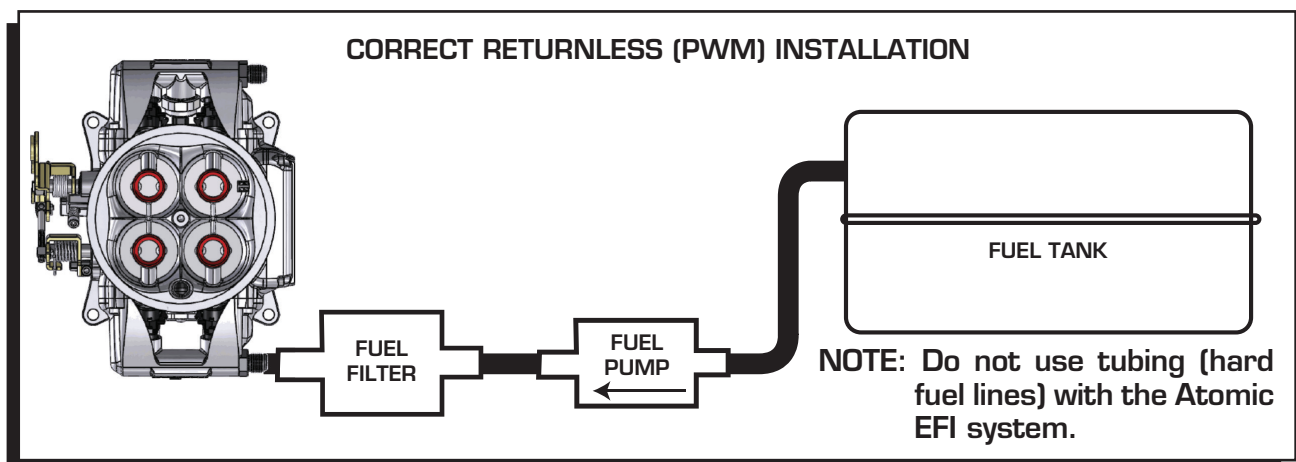

Figure 1 Atomic Returnless Fuel System.

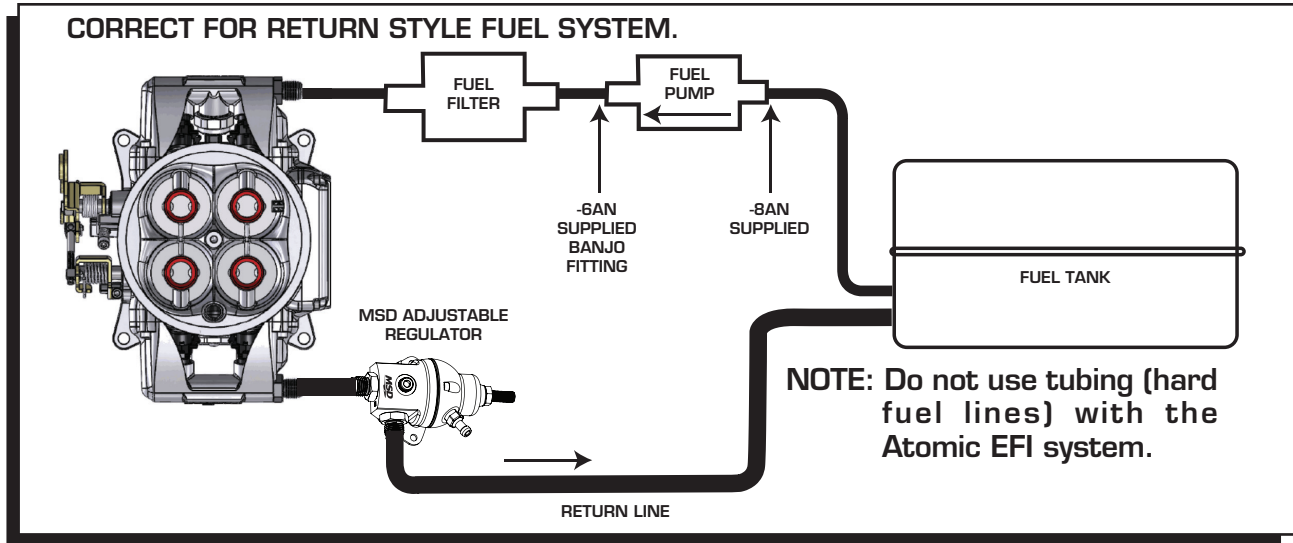

Figure 2 Atomic Return Style Fuel System.

THROTTLE BODY INSTALLATION

1. Install the new gasket and place the throttle body on the intake manifold. Make sure the throttle body is square on the intake and the linkage moves through closed throttle to wide open.
2. Secure the throttle body by tightening the four retainers evenly. Do not over tighten.
3. Transfer the linkage hardware from the carburetor to the Atomic. Any transmission brackets should also be transferred to the Atomic. A throttle return spring must be used.
4. Install the new air cleaner gasket.
6. MSD supplies one -6AN style fitting for use on the throttle body fuel inlet.
7. Install the fitting to the throttle body.

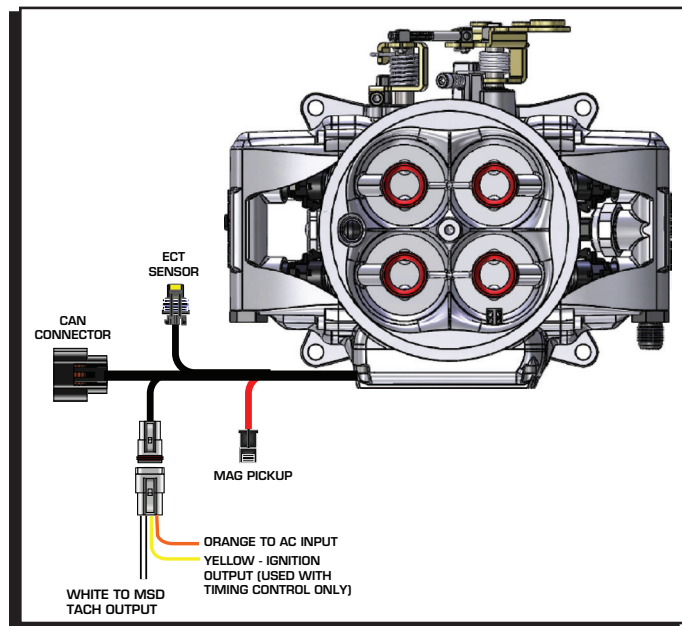

Figure 3 Throttle Body Wiring.

WIRING

There are several wires and connectors on the throttle body. Not all of these wires will be connected on every application. Following is a chart of each wire.

REQ. / OPT.	Wire Color	Description
REQ	Yellow Black	This connects to the Engine Coolant Temperature Sensor (ECT).
REQ	White	This is the tach input wire for the EFI. It connects to the tach output of an MSD Ignition Control or Ready-to-Run distributor to supply an RPM signal. Note: This wire is not used when the magnetic pickup wire is being used for ignition timing.
Optional	Yellow	This is a tach output wire. Connect this wire to the White points input wire on an MSD ignition unit only when using the Atomic to control timing. If the Atomic is not controlling timing this wire can be used as a 12 volt square wave trigger to a tachometer.
Optional	Orange	This is an AC kick-up wire. When 12 volts are supplied to this wire it will provide a small rpm "kick-up" in the idle to compensate for the added engine load from the air conditioner compressor.
Optional	Violet (+) Green (-)	This is the input for a magnetic pickup, such as from an MSD distributor. This connector is only used when the Atomic is controlling ignition timing (Mag Pickup).
REQ	CAN Connector	The 6-pin connector must connect to the Power Module. Do NOT cut this harness. MSD offers extensions in 2, 4 and 6-foot lengths if needed.

THROTTLE BLADE ADJUSTMENTS

Note that there are three adjustment screws on the linkage (Fig 4). One screw adjusts the opening of the front throttle blades. The rear blades also have an adjustment screw. These may require adjustment, depending on your engine. There is one more adjustment that controls the front and rear throttle blades opening at the same time. This is set at the factory, but each application may require slight adjustments to receive the best drivability.

For initial start-up, MSD recommends the following:

- On a street/stock type cam, turn the throttle screws ½ turn from the point where the blades first start to move.
- For a mild cam, turn the screws one additional turn from the point where the blades first move.
- For Larger cams, turn the screw 1½ turns from the point where the blades first move.

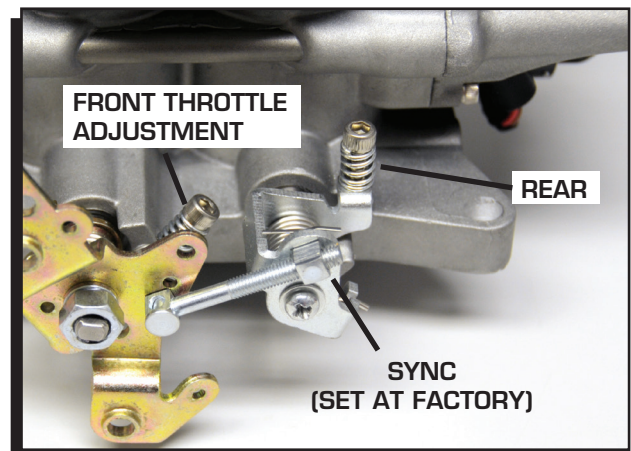

Figure 4 Throttle Body Adjustment Screws.

INSTALLATION INSTRUCTIONS

Once started, you will be able to monitor the IAC count (Idle Air Control) on the Handheld in the dash mode to improve or tune the idle. The IAC motor controls the amount of air flowing through the idle air circuit. It varies depending on the engine and operating conditions. When the engine is at operating temperature, allow the engine to idle and monitor the IAC count in gear (automatic, or in neutral for standard). This count can range from 0 – 175, a rule of thumb would be 10 - 20 with a manual transmission and 5-15 in gear with an automatic (less is ok, even 0). If the count is too high, the IAC is trying to open too much and the blades should be adjusted open to stabilize the idle. If the engine will not idle at the target RPM and the IAC count is at zero, the throttle blades have been opened too far. Make any adjustments equally in front and rear using small steps such as a quarter turn at a time.

How to return the throttle blades back to the zero (starting position)

1. Turn both screws CCW until there is no movement in the throttle blades.
2. Slowly turn each screw CW until the throttle blades move slightly, then back them off until there is no movement.
3. The throttle blades are at the starting position.

Note: Running too high of an idle speed in an automatic transmission equipped vehicle with a stock torque converter can cause idle issues.

Service

In case of malfunction, this MSD component will be repaired free of charge according to the terms of the warranty. When returning MSD components for warranty service, **Proof of Purchase** must be supplied for verification. After the warranty period has expired, repair service is based on a minimum and maximum fee.

All returns must have a Return Material Authorization (RMA) number issued to them before being returned. To obtain an RMA number please contact MSD Customer Service at 1 (888) MSD-7859 or visit our website at www.msdpower.com/rma to automatically obtain a number and shipping information.

When returning the unit for repair, leave all wires at the length in which you have them installed. Be sure to include a detailed account of any problems experienced, and what components and accessories are installed on the vehicle. The repaired unit will be returned as soon as possible using Ground shipping methods (ground shipping is covered by warranty). For more information, call MSD at (915) 855-7123. MSD technicians are available from 7:00 a.m. to 5:00 p.m. Monday - Friday (mountain time).

Limited Warranty

MSD warrants this product to be free from defects in material and workmanship under its intended normal use*, when properly installed and purchased from an authorized MSD dealer, for a period of one year from the date of the original purchase. This warranty is void for any products purchased through auction websites. If found to be defective as mentioned above, it will be repaired or replaced at the option of MSD. Any item that is covered under this warranty will be returned free of charge using Ground shipping methods.

This shall constitute the sole remedy of the purchaser and the sole liability of MSD. To the extent permitted by law, the foregoing is exclusive and in lieu of all other warranties or representation whether expressed or implied, including any implied warranty of merchantability or fitness. In no event shall MSD or its suppliers be liable for special or consequential damages.

*Intended normal use means that this item is being used as was originally intended and for the original application as sold by MSD. Any modifications to this item or if it is used on an application other than what MSD markets the product, the warranty will be void. It is the sole responsibility of the customer to determine that this item will work for the application they are intending. MSD will accept no liability for custom applications.