

# **MSD** INSTALLATION INSTRUCTIONS

## **Mallory E-Spark™ Breakerless Conversion Kit For Mallory Points Distributors**

Note: This product is legal in California only for racing vehicles which may never be operated upon a highway.

**IMPORTANT:** All kits listed below must be used with an ignition ballast resistor (or loom resistance wire) to prevent module failure. If your vehicle is not equipped with a ballast resistor or loom resistance wire, Mallory Ballast Resistor (Part No. 700) or Mallory Coils 29219, 29450 or 30450 (which are internally ballasted) may be used. These kits do not work with vacuum advance distributors.

### **Parts Included in this kit:**

1 - E-Spark™ Plate Assembly	1 - Wire Connector
1 - Wire Harness	1 - Grommet, 3-Hole (Marine Approved)
1 - Rotor/Shutter Wheel Assembly (PN 559 contains 2 rotor/shutter wheel assemblies)	2 - Pins, Aluminum
	1 - Thrust Button

### **APPLICATIONS**

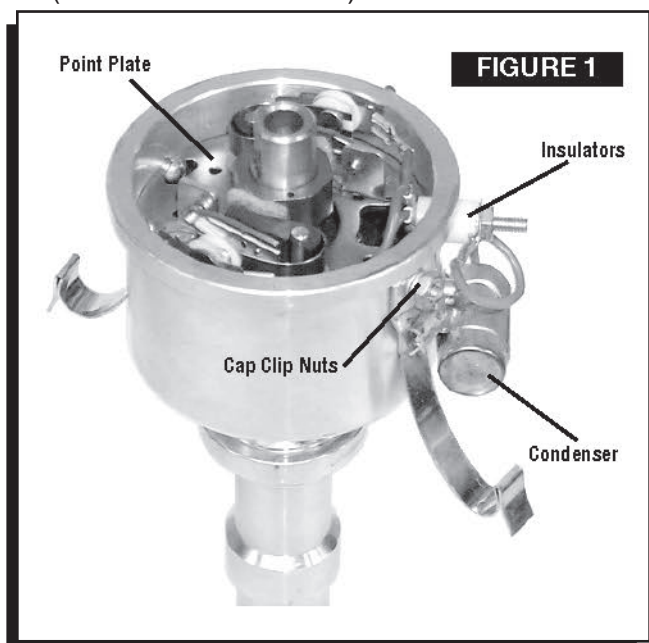
Part No. 61004M	Mallory 8 cylinder point distributors (automotive and marine) which use a standard stack cap (Part No. 209 or 209D)
Part No. 61005M	Mallory 8 cylinder point distributors (automotive and marine) which use a flat cap (Part No. 221 or 221B)
Part No. 61006M	Mallory 6 cylinder point distributors (automotive and marine) which use a standard stack cap (Part No. 270 or 270B)
Part No. 61007M	Mallory 6 cylinder point distributors (automotive and marine) which use a mini bowl cap (Part No. 226 or 226B)
Part No. 61008M	Mallory 4 cylinder point distributors (automotive and marine) which use a standard stack cap (Part No. 271 or 271B)
Part No. 61009M	Mallory 4 cylinder point distributors (automotive and marine) which use a mini bowl cap (Part No. 225 or 225B)

**WARNING:** You must install the E-Spark™ Conversion Kit exactly as shown in these instructions. After the kit is installed—and before you start the engine— check all wiring again. Mis-wiring will cause the E-Spark™ Ignition to fail immediately.

### **INSTALLATION**

**Step 1** - Remove the cap and rotor, then remove the con- denser. Remove the plastic insulators (see Figure 1).

**Step 2** - Loosen the 2 nuts that hold the cap clips/ brackets in place (see Figure 1).



**Note:** To loosen the nuts on a marine distributor, the aluminum pins in the brackets may need to be cut in two and removed. Replacement pins are provided.

**Step 3 -** Remove the point plate assembly by lifting it out of the housing (see Figure 1).

**Step 4 -** Use a 2-arm or 3-arm puller and the thrust button (provided) to remove the cam from the rotor sleeve (Figure 2).

**WARNING:** Do not try to remove the cam by prying on it with a screwdriver(s). This will damage the advance assembly.

**Step 5 -** Install the E-Spark™ plate assembly into the housing. Make sure that the cut-out in the plate is directly below the hole in the housing where the wires will exit (Figure 3).

**Step 6 -** Tighten the two nuts that hold the cap clips/brackets in place. This also secures the E-Spark™ plate.

**Step 7 -** Marine Distributors Only replace the cap clips using the new aluminum pins provided.

**Step 8 -** Install the wire grommet. Lubricate the wires with light oil. Run the wires through the grommet and out of the distributor housing (Figure 3).

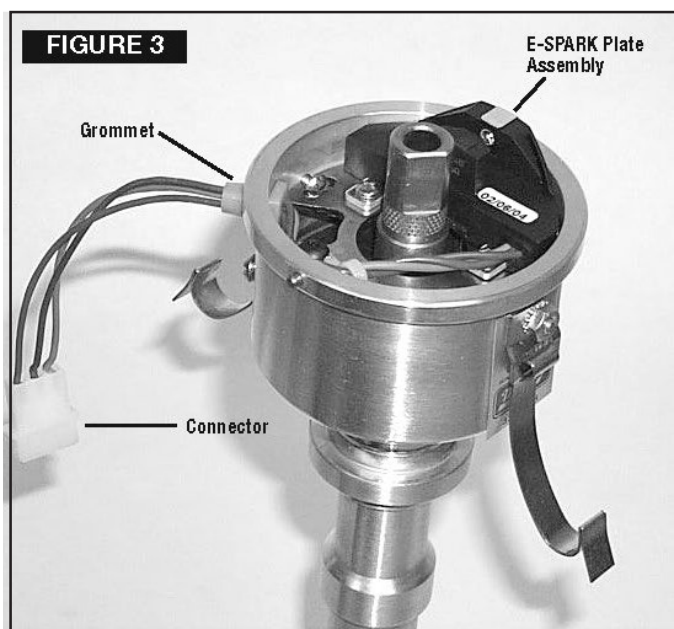
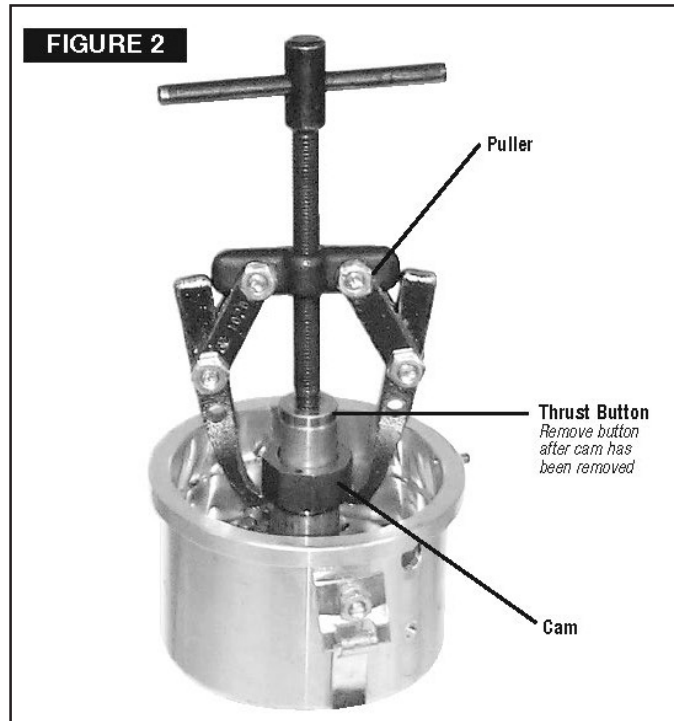
**Step 9 -** Install the connector onto the wires. Be sure the wires are in the correct positions (Figure 4).

**Step 10 -** Install the rotor/shutter wheel assembly. Make sure that the rotor is fully seated and that it does not rub the module wires. Replace the cap.

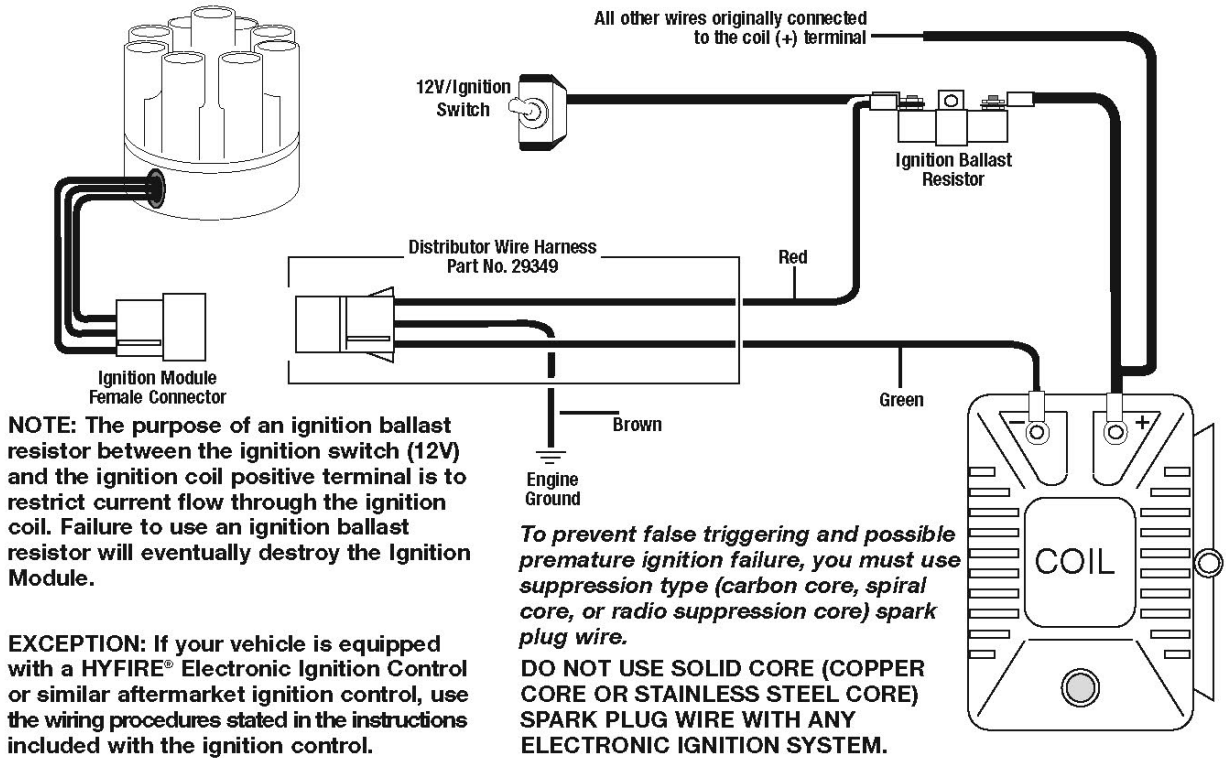
**Step 11 -** If you removed the distributor to install the E-Spark™ Conversion Kit, reinstall the distributor in the engine.

**Step 12 -** Connect the wire harness to the connector. Connect the 3 wires to the correct locations, as shown in Figures 5 and 6.

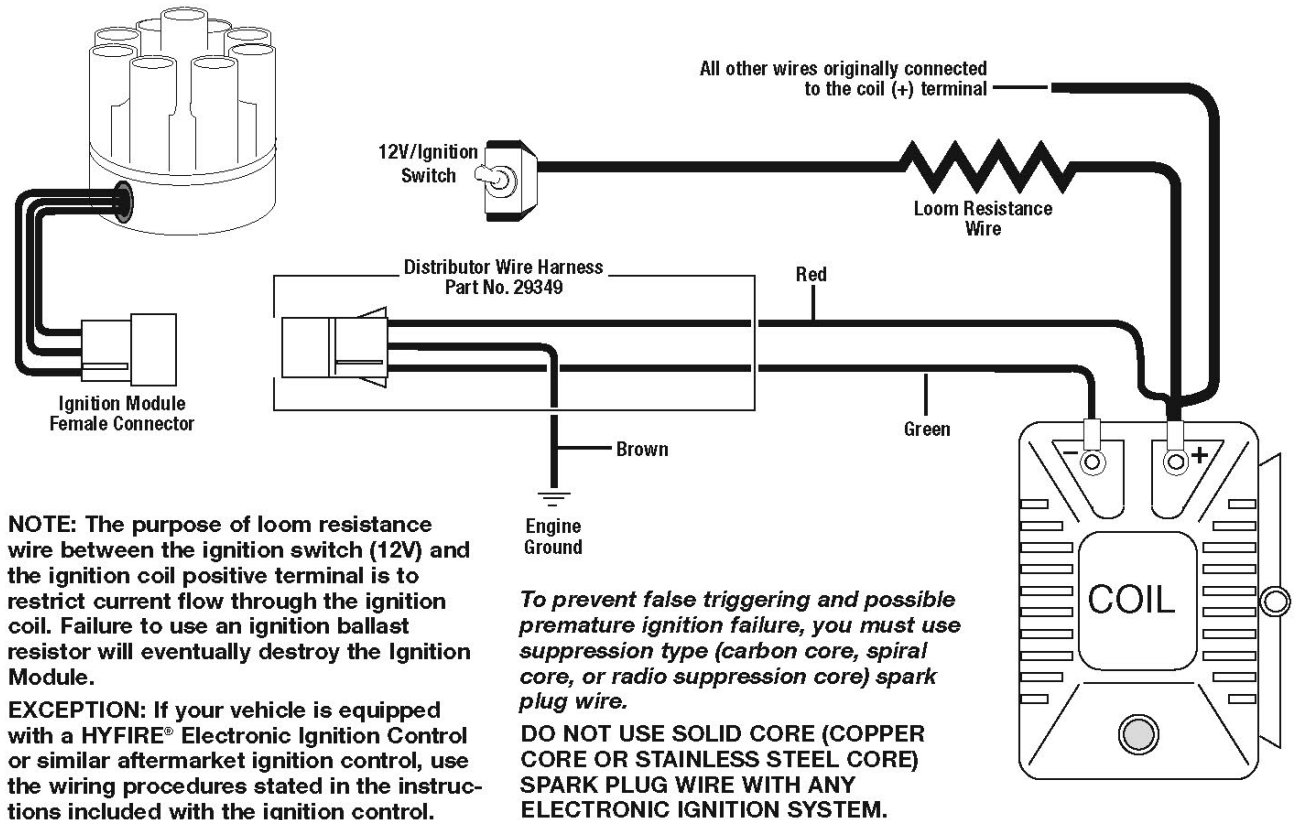
**Step 13 -** Set the ignition timing. Start the engine and recheck timing.



**FIGURE 5** EQUIPPED WITH EXTERNAL BALLAST RESISTOR

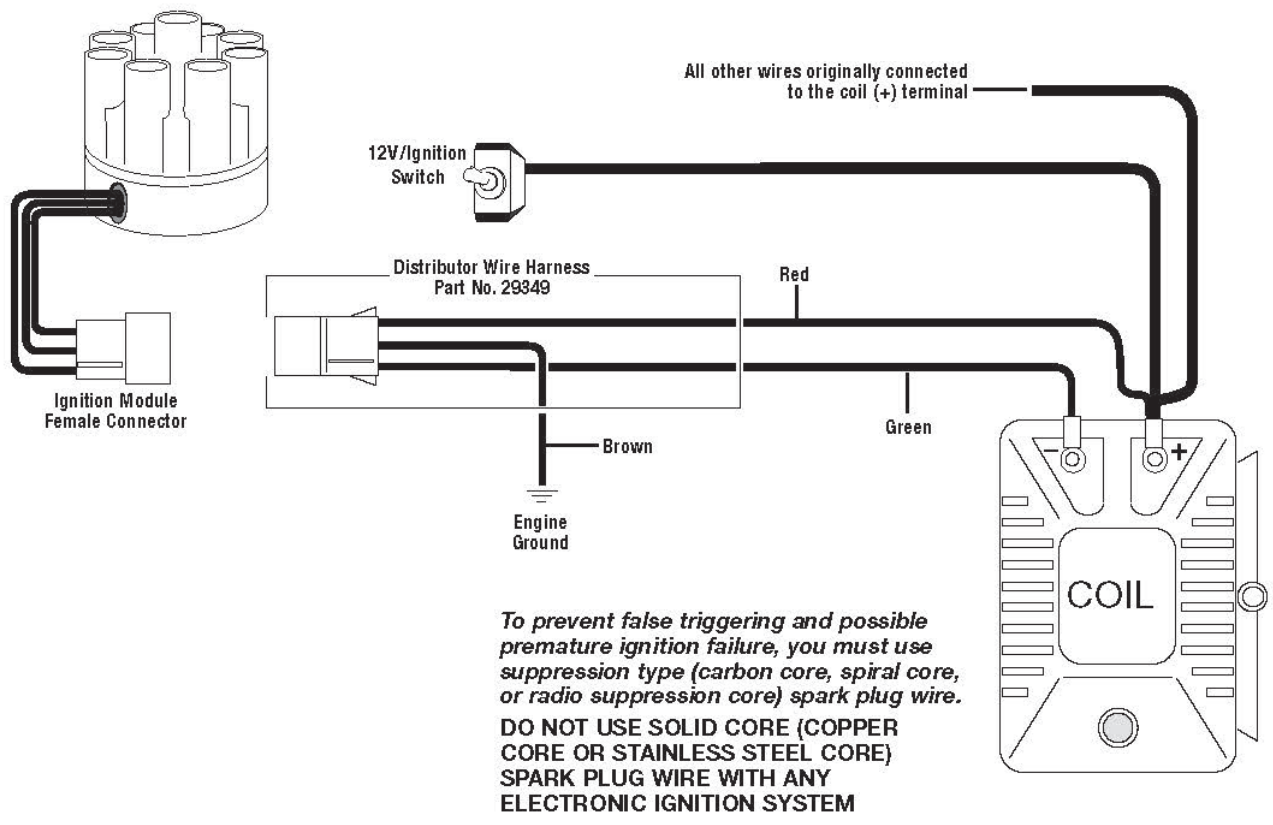


**FIGURE 6** EQUIPPED WITH LOOM RESISTANCE WIRE



# MSD INSTALLATION INSTRUCTIONS

**FIGURE 7** EQUIPPED WITH 29219, 29450, OR 30450 COILS ONLY



**FIGURE 8** FOR MARINE USE ONLY

After installing your Mallory Electronic Distributor, the Electronic Shift Assist (ESA) circuit in your boat must be function tested. Shifting into or out of gear can be difficult or impossible if the ESA circuit is malfunctioning or missing. If you encounter shifter related problems with your boat after installing any Mallory distributor, contact the Mallory Technical Service Department at 216.688.8300.

All Mallory Marine Electronic Ignition Systems in Outboard Marine Corp (OMC) applications with a shift box require the gray wire from the coil to the shift box be modified as follows:

The gray wire from the coil (-) terminal triggers the shift box. The gray wire should be cut or disconnected at the coil terminal so that the components shown here can be inserted. Solder all connections and confirm correct operation, then insulate well, especially if the boat is being used in salt water.

