

*Edelbrock*

# PRO-FLO 4+

ELECTRONIC FUEL INJECTION

## INSTALLATION INSTRUCTIONS FOR COYOTE ENGINES

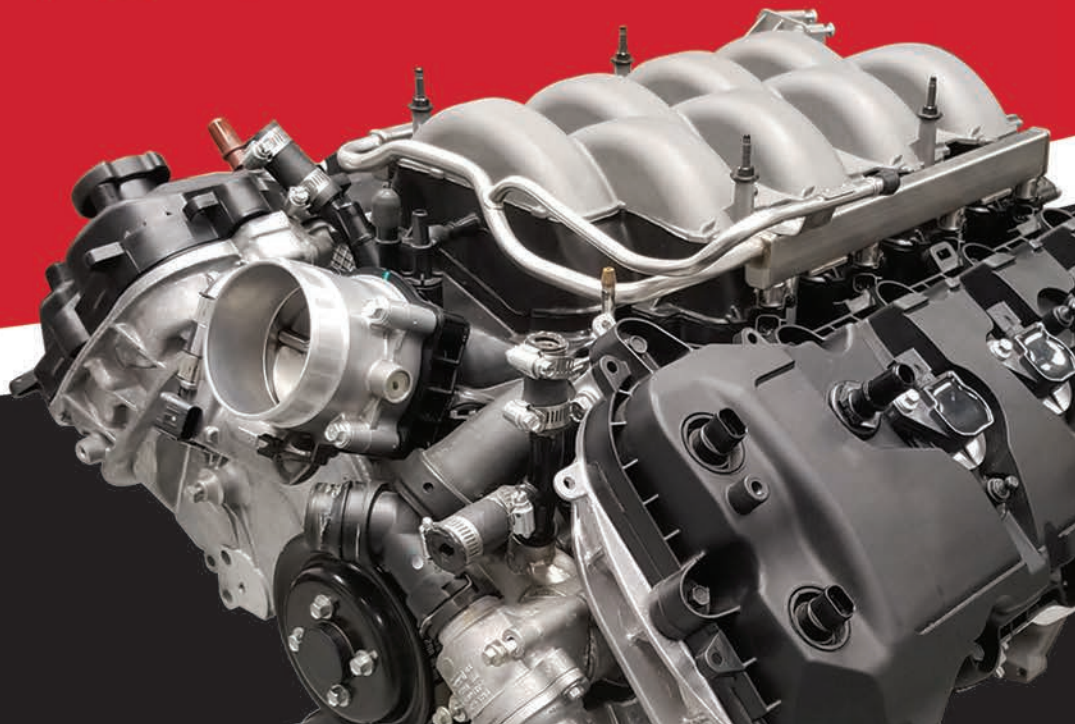

36110 / 36160

# TABLE OF CONTENTS

Introduction .....	1
Recommended & Required Components .....	2
What you need to know .....	2
Tools and System Requirements.....	3
Important Warnings.....	4
Fuel System Requirements .....	5
Primary Kit Components .....	6
Main Harness Layout .....	7
Wideband Oxygen Sensor Installation.....	8
Pro-Flo 4 Plus Installation .....	9-11
- Drive By Wire Notes.....	10
E-Tuner 4 Plus Overview.....	11-15
Digital Display .....	16
Getting Familiar with PRO-FLO 4 PLUS / E TUNER PLUS .....	17
Pro-Flo 4 Plus EFI Setup Wizard Map Matrix .....	17
Chassis Harness Diagram .....	18
Main Engine Harness Diagram.....	19
Sub-Engine Harness Diagram - 2011-2015 Models .....	20-21
Knock Sensor Harness Diagram .....	22
Fan Relay Harness Diagram .....	23
Warranty .....	24

## INTRODUCTION

Thank you for selecting the *Edelbrock Pro-Flo 4 Plus EFI system*. This Instruction manual contains the information necessary for the installation and basic setup of the components in this kit.

The Edelbrock Coyote Harness and ECU Kit is intended to be a plug and play application for most factory Coyote engine configurations while employing a factory intake system and drive-by-wire components. This EFI System will also function on applications using other manufacturers intake manifolds. Due to the many design variances of the Coyote Engine family, some additional components are necessary to complete assembly. Please see the parts list on page 2 for suggested components and sources.

NOTE: This EFI System does not support AFM/DOD EFI functions. All related components must be removed or deleted.

Included in this kit is a Bluetooth Wireless Tablet with the *Edelbrock E Tuner 4 Plus* Calibration App pre-loaded. The Pro Flo 4 Plus EFI system can be paired via Bluetooth Connection with the *E Tuner 4 Plus* Android Software App that will enable a calibration setup wizard, real-time system performance monitoring and tools for making fine tuning adjustments.

**CAREFULLY STUDY AND UNDERSTAND ALL INSTRUCTIONS BEFORE BEGINNING THIS INSTALLATION. PLEASE READ ALL WARNINGS AND NOTES ON PAGES 4 AND 5** as they contain valuable information that can greatly simplify your installation and prevent damage to your vehicle. Should you require assistance please contact the **EDELBRÖCK EFI Tech Support at: 800-416-8628**, 7am-5pm PST, Monday through Friday.

- This installation can be accomplished using common tools and procedures. However, it is highly recommended to have a solid understanding of automotive repairs and modifications and are familiar with and comfortable working on your vehicle's fuel system. If you do not feel comfortable working on your vehicle, it is recommended to have the installation completed by a professional mechanic.

- Before beginning the installation, verify that all components are present in the box. Inspect each component for damage that may have occurred in transit. If any parts are missing or damaged contact Edelbrock Technical Support at (800) 416-8628, not your parts distributor.

**PROPER INSTALLATION IS THE RESPONSIBILITY OF THE INSTALLER. IMPROPER INSTALLATION WILL VOID ALL MANUFACTURER'S STANDARD WARRANTIES AND MAY RESULT IN POOR PERFORMANCE AND/OR DAMAGE TO THE ENGINE AND/OR VEHICLE.**

## RECOMMENDED COMPONENTS

Some of these items may need to be purchased to complete your installation. Read this entire manual before purchasing any items on this list. Question? Call the Tech Line at (800) 416-8628.

PART DESCRIPTION	PART#	VENDOR
<input type="checkbox"/> Harness, Radiator Fan Relay Module, Plug n' Play	36115	Edelbrock
<input type="checkbox"/> Harness, Fuel Pump with Relay	3534	Edelbrock
<input type="checkbox"/> Harness, Knock Sensor* - Ford Coyote	36125	Edelbrock
<input type="checkbox"/> Harness, O2 Sensor Extension - Short	36152	Edelbrock
<input type="checkbox"/> Universal EFI Fuel Sump System	36031	Edelbrock
<input type="checkbox"/> Return Style EFI Fuel System	3604	Edelbrock
<input type="checkbox"/> Accelerator Pedal - Ford		Ford

## WHAT YOU NEED TO KNOW

- PF4 Plus EFI for Ford Coyote applications implements speed density fueling strategy with an included MAP & IAT sensor which eliminates the factory MAF sensor, air inlet piping, and air box. This provides unlimited air intake design options. Map Sensor and Inlet Air Temperature Sensor included in kit
- Works with stock sized Ford factory 80mm DBW throttle bodies or 87mm GT350 throttle body
- Quad variable cam control – plug and play, no calibrating necessary. No modifiers in E Tuner 4 Plus App.
- Supports both the 2011-2014 standard VCT phasers and 2015-2017 “mid-lock” VCT phasers
- Early Gen I requires Gen II Ford BR3Z-6M280D or equivalent actuators
- All Calibrations standard 58 psi fuel pressure
- Alternator Control is set to regulate at 13.8 Volts, non adjustable
- Calibrated for use with Factory Injectors
- Requires deleting OF IMRC/CMCV functions
- Stock EVAP System not supported
- Factory Ignition Coils or equivalent must be retained
- For Knock functions, additional Knock Harness kit #36125 is required. Functions using factory Ford knock sensors.
- Functions with only stock configuration engines, no major engine modifications. (Initial release only)

## ***E-TUNER* 4 PLUS SOFTWARE UPDATES**

Edelbrock may periodically releases improved versions of the **E-Tuner 4 Plus** app software. These updates can include improvements to pre-installed calibrations, or additional calibration updates to the user interface to improve the overall functionality of the software. It is recommended to check the Google Play Store or the Edelbrock website to verify that you have the most recent version of the app.

**WARNING:** *The Edelbrock E-Tuner Software is intended to be used as a hands-free tuning tool and gauge display. Any function that requires prolonged attention should only be performed after coming to a complete stop. Distracted driving is extremely dangerous and illegal in most states. If adjustments are to be made during driving, always stop the vehicle in a safe location before performing any adjustments, or have a passenger perform the necessary adjustments. Please check with your local laws for legal mounting locations in your vehicle.*

### **TOOLS AND SYSTEM REQUIREMENTS**

*Use the following checklist for items needed.*

- Wrench / Socket Set
- 7/8" Oxygen Sensor Socket or Equivalent
- Pliers (channel locks and hose clamp)
- Screwdrivers (Phillips and Flathead)
- Shop Rags
- Loctite 598 OEM High Temperature Silicone Gasket (O2 Sensor Compatible)
- Vehicle Wiring Diagram (if available)
- Thread Sealer
- High-Heat Anti-Seize Compound
- 180°F Thermostat
- Resistor Type Spark Plugs (*Use correct heat range for your particular application*)
- EFI Fuel System (*See fuel system recommendation*)
- Fuel fittings (*Additional fittings may be required depending on routing preferences. Visit [www.russell.com](http://www.russell.com)*)
- 30 AMP Automotive Relay (*If using electric fans - One relay required for each accessory*)

### **FUEL PUMP SELECTION**



The **Pro-Flo 4 Plus** ECU is configured to directly power a fuel pump. The ECU's pump circuitry is rated for 10 Amps. Before connecting the fuel pump lead in the wiring harness to any fuel pump, the fuel pump's current draw rating must be checked – see pump manufacturer's specs for this information.

A conventional Walbro 255 LPH type pump or equivalent is typically acceptable. Many larger, high output performance fuel pumps will draw more than 10 amps, requiring the use of a relay. Damage caused by improper fuel pump selection is NOT covered under warranty. See FUEL SYSTEM REQUIREMENTS section for more information, refer to fuel pump relay harness diagram on page 5.

**NOTE:** For a plug and play solution to your fuel delivery needs, refer to the Edelbrock Fuel Pump Relay Harness, part# 3534.

## **IMPORTANT WARNINGS**

### **O2 SENSOR BUNG INSTALLATION**

It is suggested that the O2 sensor bung be installed by a professional muffler shop prior to the installation of the Edelbrock **Pro-Flo 4 Plus** EFI system. DO NOT drive the vehicle with the O2 sensor unplugged, sensor damage **will** occur. An O2 sensor bung plug is provided for your convenience. Refer to Page 8 for the O2 sensor installation procedure.

### **EXHAUST SYSTEM**

For the Self Tuning function to properly operate, **the exhaust system must be completely sealed from header flange surface at cylinder heads to tailpipe**. The exhaust system should be completely inspected prior to installing the **Pro-Flo 4 Plus** EFI system. All gaskets and hardware should be replaced. All hardware torques should be checked on regular bases.

### **AUTOMATIC TRANSMISSION CHECK**

For best performance, economy, and emissions, the transmission kick down and shift points must be checked before and after the **Pro-Flo 4 Plus** EFI installation.

### **IGNITION COIL**

Stock/OEM coils or equivalent replacements are acceptable to use. Ford Coyote coils are not compatible with CDI ignition amplifiers.

### **CHARGING SYSTEM**

The **Pro-Flo 4 Plus** EFI System requires a constant battery voltage of 12.0 volts or greater to operate properly. Recommended battery capabilities are: 1000CA @32°F / 800CA @0°F. The vehicle's battery must be in good operating condition capable of maintaining a proper charge at all times. Verify the vehicle's charging system is operating properly and that the system voltage maintains 12.0 volts, or greater, at all times. All chassis grounds must be tight and clean. A ground cable from the engine block to chassis should be employed. All battery cables must be in good condition providing a clean tight connection to the battery.

### **BATTERY CHARGER PRECAUTIONS - PLEASE ADHERE TO THE FOLLOWING GUIDELINES OR DAMAGE TO ECU MAY OCCUR.**

- Be sure the battery has a full charge prior to attempting to start the vehicle.
- Never use the "engine start or jump start" setting on a charger to start the engine.
- Do not set the battery charger above 10 amps when charging.
- Never turn on the ECU or attempt to start the engine with the battery charger connected.
- Make sure the charger is not charging over 18.0 volts.
- If the battery is completely discharged, it is best to disconnect the negative terminal on the battery when charging.

### **COOLING SYSTEM**

The minimum temperature requirement for the thermostat is 180°F.

### **AFM/DOD**

This EFI System does not support AFM/DOD EFI functions. All related components must be removed or deleted.

### **EMISSION CONTROLS**

The Edelbrock **Pro-Flo 4 Plus** EFI system will not accept stock emissions control systems. Check your local emissions laws for requirements before installing the **Pro-Flo 4 Plus** EFI system. ***This system is not legal for use on pollution-controlled motor vehicles.***

### **FUEL REQUIREMENTS**

The **Pro-Flo 4 Plus** EFI system uses a wideband oxygen (O2) sensor, unleaded fuel must be used at all times. **Using leaded fuels will damage the O2 sensor and void your warranty.** If leaded fuel is present in your fuel tank, the tank must be drained and filled with unleaded fuel. It is also recommended to have a full fuel tank before operating the vehicle (*after the installation*).

**NOTE:** E85 fuels are not compatible with any **Pro-Flo 4 Plus** EFI systems.

**FUEL SYSTEM REQUIREMENTS (Fuel system not included in kit)**

The *Pro-Flo 4 Plus* EFI system requires a high pressure fuel system providing 58-60 psi of fuel pressure with a flow rating of 57 GPH (215 liter/hr @58psi). These fuel system requirements can support up to 600 HP. The following recommended options are available separately.

**Fuel Pressure Regulator Vacuum Reference:** The Fuel Pressure Regulator **MUST** reference manifold pressure to ensure a proper fuel pressure differential during an injector opening event under high vacuum conditions. The vacuum reference will lower fuel pressure slightly under idle and cruise conditions. The amount of pressure reduction will vary from engine to engine. During wide open throttle conditions, the fuel pressure should read the set point value of 58psi depending on your application. The fuel pressure regulator should always be set to the target pressure with the vacuum reference hose disconnected from the Fuel Pressure Regulator. The hose from the manifold **MUST** be plugged to prevent a vacuum leak when setting the pressure. Remove the plug and reconnect the vacuum line to the fuel pressure regulator after target pressure is achieved.

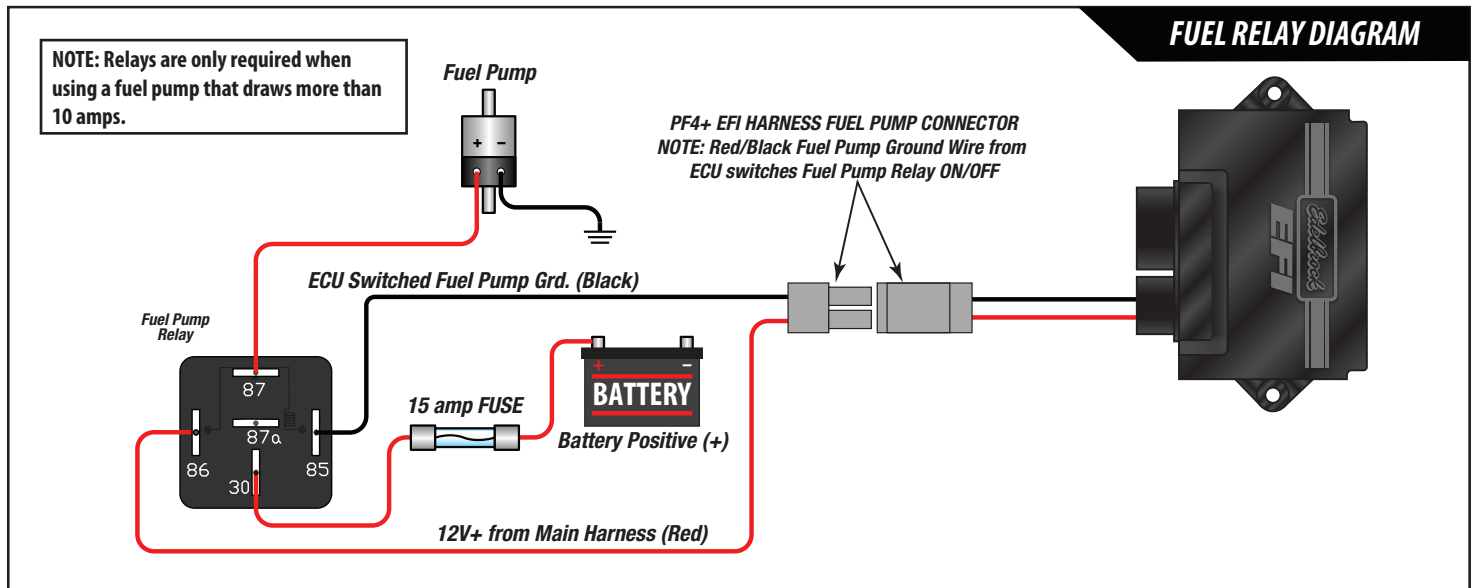
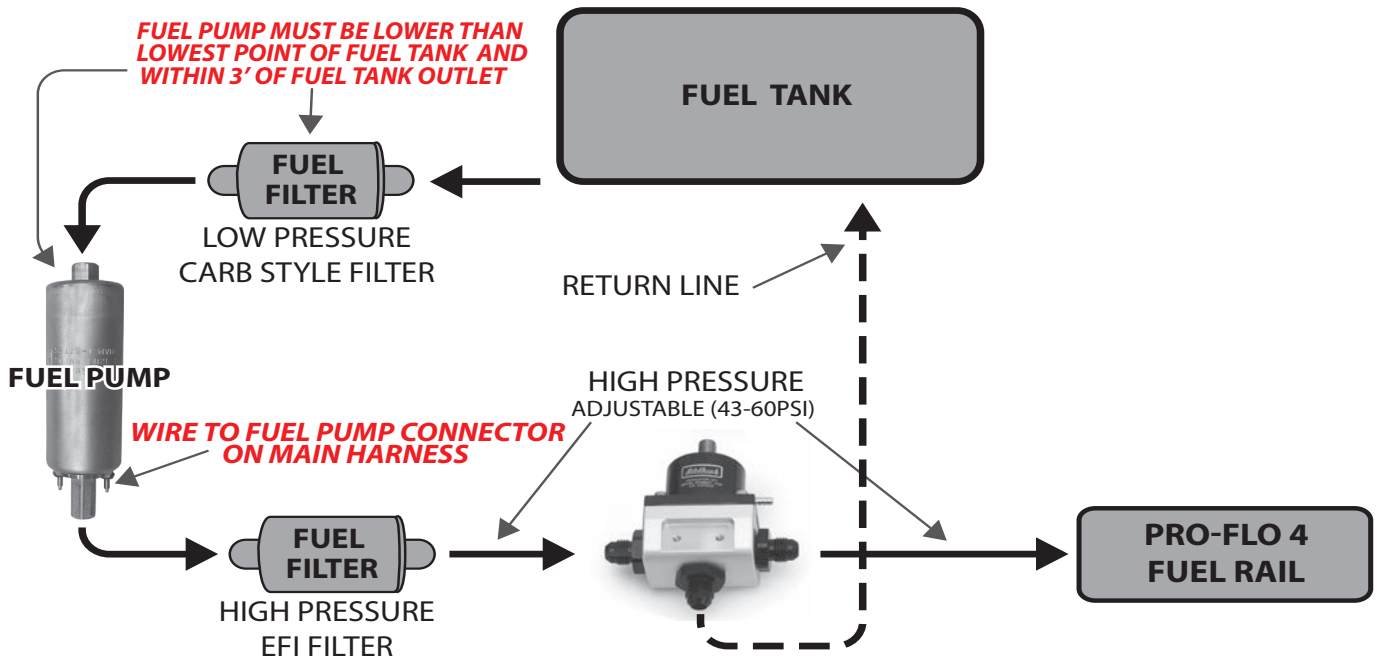

## PRIMARY KIT COMPONENTS

(Images are for reference only and may not represent actual components.)

Item	P/N	QTY.	Description
1	37-3605	1	7" Tablet (if applicable)
2	37-3604	1	Oxygen Sensor
3	37-1033	1	APP Harness (Pedal)
4	37-1031	1	O2 Extension Harness 48"
5	37-3616	1	Pro-Flo 4 Plus ECU
6	37-1024	1	Main Engine Harness
7	37-1026	1	Chassis Harness
<b>KIT# 36110 (2011-2015)</b>			
8	37-1025	1	Sub Engine Harness
<b>KIT# 36160 (2016-2017)</b>			
8	37-1022	1	Sub Engine Harness

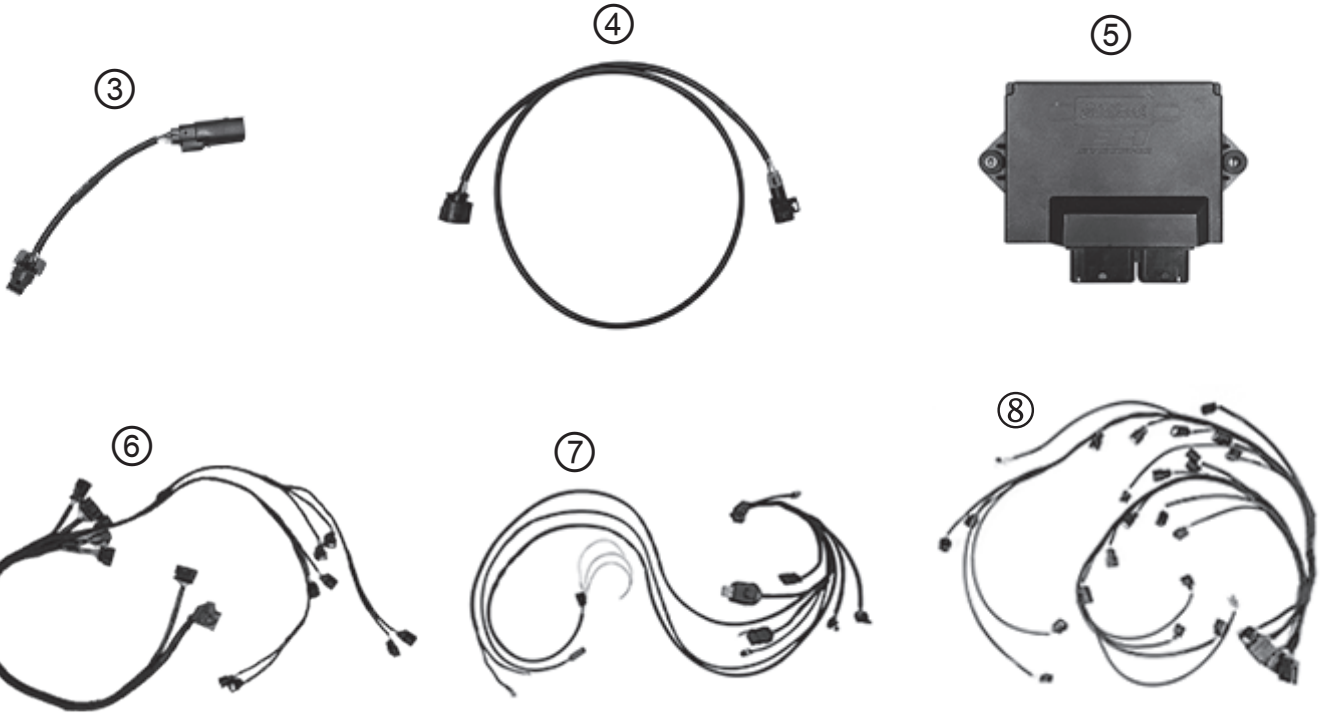

## MAIN HARDWARE

(Images are for reference only and may not represent actual components.)

Item	P/N	QTY.	Description
1	36-3505	2	Sheet Metal Screw
2	52-8097	1	Oxygen Sensor Bung Plug
3	52-9710	1	Oxygen Sensor Bung
4	37-1549	1	Car Charger w/USB Cable
5	78-2004	10	11" Tie Wraps
6	37-3518	1	Air Temp Sensor & Grommet
7	24-5022	1	Fuel Pressure Sensor

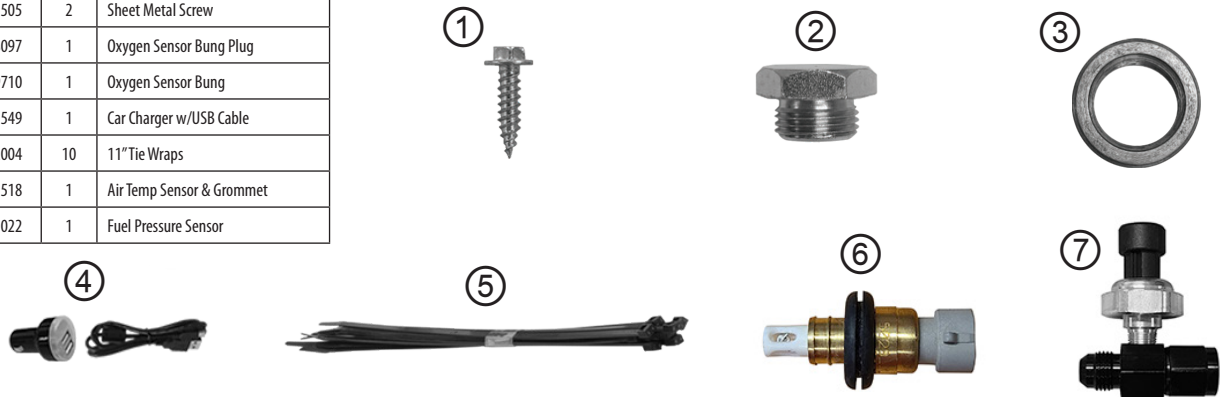

# MAIN HARNESS LAYOUT

## 37-1024 Main Engine Harness

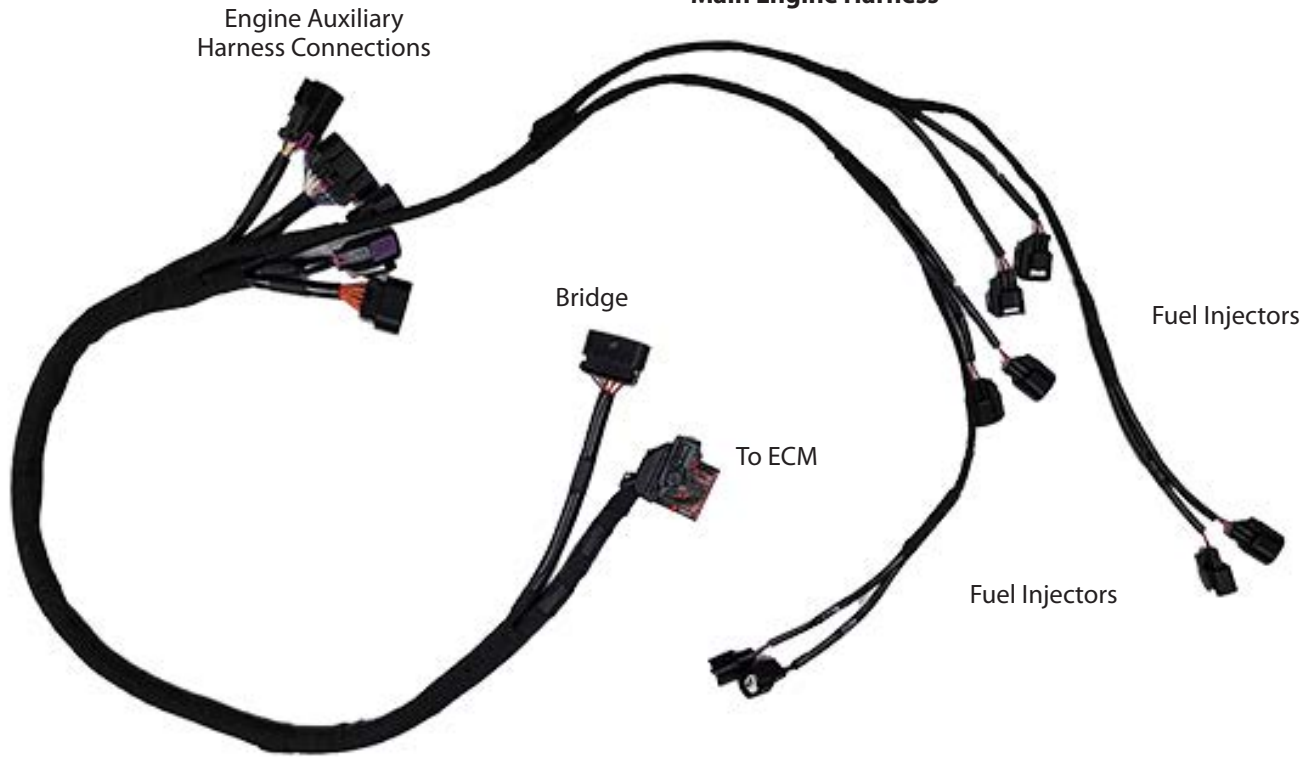

## 37-1026 Chassis Harness

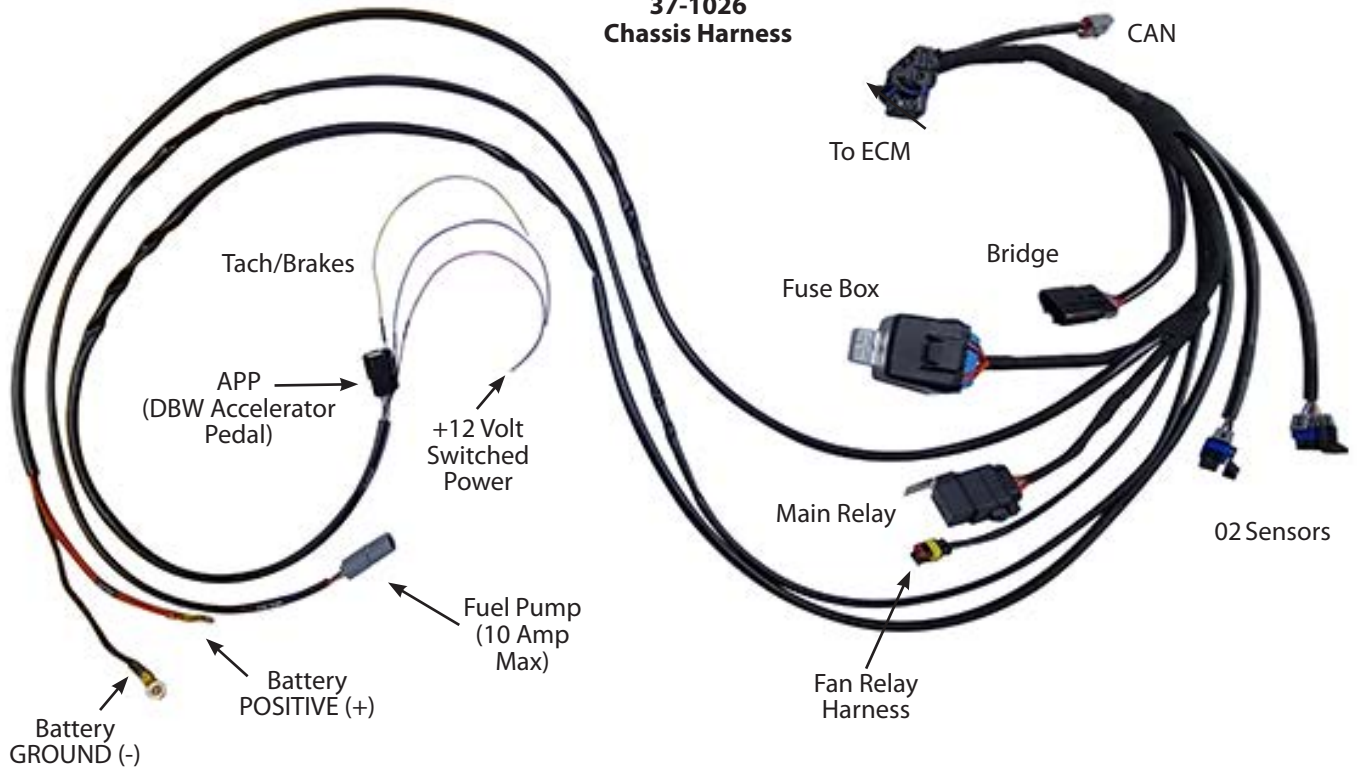



## **WIDEBAND OXYGEN (O2) SENSOR INSTALLATION PROCEDURE**

The O2 sensor must be installed in the exhaust system using the supplied O2 sensor bung from the hardware bag. The O2 sensor is required to measure the oxygen content of the exhaust gas which is used by the ECU to manage fuel delivery under closed loop control.

**NOTE:** It is suggested that the O2 sensor bung be installed by a professional muffler shop prior to the installation of the Edelbrock Pro-Flo 4 Plus EFI system. DO NOT drive the vehicle with the O2 sensor unplugged as this will damage the O2 sensor. An O2 sensor bung plug is provided for your convenience.

**WARNING:** A properly sealed exhaust system is critical for the Pro-Flo 4 Plus EFI to function properly. Any air leaks in the exhaust system, upstream of the O2 sensor, will skew the O2 sensor's output resulting in improper calibration which can lead to engine damage. Use locking type hardware to secure exhaust headers to cylinder heads and exhaust collector to mid-pipe. DO NOT USE NYLOC NUTS. Re-torque exhaust hardware on a regular basis to ensure exhaust leaks do not occur. Improper installation of the O2 sensor and any damage that may result is not covered by any Edelbrock Warranty.

**WARNING:** Be sure any RTV Silicone used to seal the exhaust system is compatible with Oxygen Sensors. This information will be found on the silicone tube packaging.

1. The O2 sensor bung must be installed in the exhaust system as close to the engine as possible, after the header collector and before the catalytic converter (if equipped) in a location that it can read an average all pipes in collector. This location must be approximately 10° above horizontal and within reach of the O2 sensor harness connector on the Pro-Flo 4 Plus main harness. **NOTE: There must be at least 24" of exhaust pipe after the O2 sensor. Open headers or "zoomies" will cause the sensor to read incorrectly.**
2. Mark the drilling location on the exhaust system pipe with a permanent or paint marker. Check the proposed mounting location to ensure the clearance for the O2 sensor is adequate and that the O2 sensor connector on the main harness will reach the O2 sensor location. Make sure to take engine movement into consideration when checking for clearance.
3. Drill a 5/8" hole at your mounting location. Deburr and clean the hole as needed.
4. Fit the provided bung onto the hole opening. Secure the bung with a clamp and weld the bung into place.
5. Once the installation of the bung is complete, make sure to clean the threads of the fitting to ensure it's free of debris. **NOTE: The O2 sensor bung uses an M18 x 1.5 thread pitch.**
6. If you are ready to install the Pro-Flo 4 Plus EFI system, proceed to Step #9 to install your O2 sensor. Otherwise, if your Pro-Flo 4 Plus EFI System will be installed at a later time, temporarily install the O2 sensor bung plug supplied in the hardware bag with a 7/8" wrench. This will allow you to drive the vehicle until the O2 sensor is installed.
7. When you are ready to begin installation of the Pro-Flo 4 Plus EFI system, remove the O2 sensor bung plug.

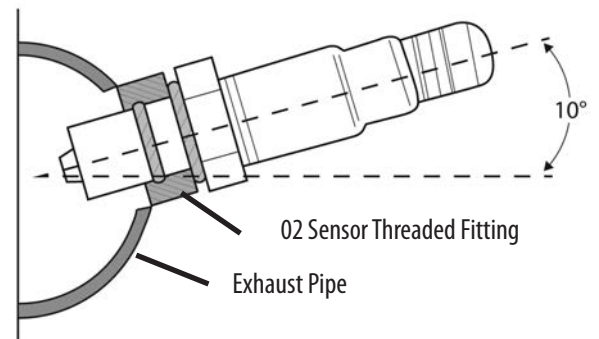

### 1.0 ECU Mounting Consideration Notes:

- ❑ 1.1 Fasten ECU using the 2 fasteners provided in this kit. If routing the wiring harness through the bulkhead or any sheet metal, a grommet is required to prevent damage.
- ❑ 1.2 ECU Harnesses are designed for ECU mounting locations in the Engine compartment.
- ❑ 1.3 ECU should be located such that it isn't exposed to excessive heat or vibration.
- ❑ 1.4 ECU should be mounted such that it is as far away from spark plug wires, CD ignition boxes, or other "electrically noisy" devices as is reasonably possible.
- ❑ 1.5 Make sure the connector end of the ECU is pointed DOWN so fluids can't ingress into the ECU terminals. (Fig. 1)
- ❑ 1.6 Prior to final ECU mounting verify all injector connectors, engine sub harness connectors, fuse box, and relays reach appropriate destinations.

### 2.0 Main Engine Harness Routing and Installation

- ❑ 2.1 Ensure all connectors are connected in their appropriate location and are in the locked position.
- ❑ 2.2 ECU Connector (Required) Plug Large over center latching connector on Chassis Harness into the larger of the two connectors on the ECU.
- ❑ 2.3 Injector Connections. (Required) The Fuel Injector Connectors are labeled by cylinder #. Fuel Injector connectors use appropriate housing for USCAR EV6/EV14 Injectors.
- ❑ 2.4 Knock Sensor (Optional) Connect to the Knock Sensor(s). Coyote engines will have a knock sensor located in the center valley of the engine

### 3.0 Chassis Harness Routing and Installation

- ❑ 3.1 ECU Connector. Plug Large over center latching connector on Chassis Harness into the smaller of the two connectors on the ECU. (Fig. 2)
- ❑ 3.2 Fuse Box/Relay. Mount the Main Relay and Fuse Box in an easily accessible, dry, secure location away from excessive heat sources.
- ❑ 3.3 Bridge (Required) Connect Bridge Connection between Main Engine Harness and Chassis Harness for shared ECU Input and Outputs.
- ❑ 3.4 Complete the following Chassis Harness connections.
- ❑ 3.5a O2 Sensor. (Required) Connect the supplied 48" O2 extension Harness into the Chassis Harness Connector labeled O2#1, connect other end to O2 Sensor supplied in kit.
- ❑ 3.5b (Optional) For ultimate control of engine Air Fuel Ratios, an optional second O2 Sensor can be installed using O2#2 input. (additional O2 Sensor # 36126 and #36152 Extension Harness (24" required)
- ❑ 3.6 Flying Leads. Each flying lead end will require the correct corresponding connection on the vehicle.
- ❑ 3.7 Brake Switch. (Required) **IMPORTANT! INSTALLATION OF THE BRAKE SAFETY CIRCUIT IS REQUIRED. DEFEATING OR NEGLECTING TO INSTALL THIS INPUT IS DONE SO AT THE USERS OWN RISK. THE USER ASSUMES ANY AND ALL LIABILITY FOR ANY DAMAGE, AS A RESULT OF A DRIVE-BY-WIRE MALFUNCTION.** Installation: Route the Yellow/Blue wire to the Brake Light Switch on the Brake Pedal. This input acts as a DBW safety feature. The input senses +12V when the pedal is depressed. If the brake pedal is depressed enough to activate the brake light switch the ECU cancels DBW function and limits the Throttle Body opening to 10%, once the brake pedal has been released and the throttle pedal position drops below 10% the DBW functions will be re enabled.
- ❑ 3.8 Tachometer (Optional) Connects to Tach signal input. ECU Tach Signal output is 12V square wave.
- ❑ 3.9 Ignition Switch (Required) Route the Pink/Black Ignition switch Wire to a +12 Volt switched power that provides a constant +12 Volts when the key is both ON and CRANKING.
- ❑ 3.10 Fans (Optional) Electric Fan output – Each wire in this output provides a ground to trigger relay's used for the cooling fans. These outputs should never be directly connected to the fans, they are low current grounds for triggering the relay's that power the fans. They should be connected to the ground trigger of the relays . This Fan Connector mates directly with Edelbrock #36115 Radiator Fan Relay Harness for a plug-and-play solution for single or dual fans.
- ❑ 3.11 Fuel Pump (Optional) Connect your EFI fuel pump power harness to the main harness connector labeled "Fuel Pump". A grey 2 pin weather pack connector, terminals and seals are provided in your kit for connection. THE MAXIMUM CURRENT FOR THE FUEL PUMP IS 10 AMPS. DAMAGE TO THE ECU WILL OCCUR IF CURRENT IS EXCEEDED. IF THE FUEL PUMP CURRENT WILL EXCEED 10 AMPS, A FUEL PUMP RELAY IS NECESSARY. See Fuel Relay Diagram on page 5, or Fuel Pump relay Harness (Edelbrock #3534). Most Fuel Pumps supporting over 600 HP will draw current in excess of 10 AMPS. During a key ON event power and ground is provided to the fuel pump for 8 seconds then will shut OFF. This allows the Fuel Pump to pressurize the system. When the vehicle is starting and runs, the pump will turn back ON.



Fig. 1

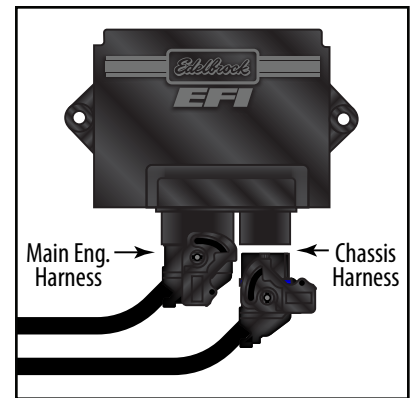

Fig. 2

- ❑ 3.12 CAN Connector. The CAN Connector is provided for communication with CAN enable devices such as Edelbrock TC transmission controller or various dash board systems with CAN Communications. Mating Connector is a Deutch DT04-4P.

CAN HI= Pin 1    CAN LO = Pin 2

- ❑ 3.13 APP Harness (Required) (Throttle Pedal Harness) Plug the APP Pedal Harness Extension into the Chassis Harness Connector labeled APP, route other end connector to vehicles Ford DBW Throttle Pedal. Follow accelerator pedal installation recommended guidelines.

#### 4.0 Drive By Wire Notes

Most drive-by-wire throttles are designed with 2 position sensors on both the throttle body and the pedal assembly. This is done as a failsafe in the event that one of the position sensors should fail. The Pro Flo 4 Plus EFI systems requires that all sensors are functioning 100% properly. If any sensor deviates from its calibrated position, the throttle body is shut down and forced to a limp home position. Factory Drive-By-Wire Throttle Bodies have a "Limp Home" position. This is the position that the throttle body is at when no power is applied. It is typically enough air flow to allow a car to move at a speed of approximately 45 mph. This varies by manufacturer, but is the case with the Ford Coyote throttle bodies this harness supports. In Limp Home Mode the throttle body may flow more air than required to idle the vehicle. Extra brake pressure may be required in gear to maintain a full stop.

**NOTE:** Pro Flo 4 Plus EFI systems only support factory Ford Coyote Throttle Bodies from 2011 thru 2017.

- ❑ Use only the DBW Harness provided in this kit
- ❑ Do not modify provided harnesses in any manner
- ❑ Be sure all DBW related harnesses are routed clear of any ignition related components

#### 5.0 Engine DBW Throttle Harness Routing and Installation

**Note:**

- ❑ 5.1 Throttle (Required) Connect Large Throttle Harness connector to Main Engine Harness connector labeled Throttle.
- ❑ 5.2 DBW (Required) Connect DBW plug to DBW Throttle Body.

#### 6.0 Engine Coil Harness Routing and Installation

- ❑ 6.1 Ignition (Required) Connect Ignition plug on the coil harness to the Main Engine harness connector labeled "Ignition".
- ❑ 6.2 Engine Position (Required) Connect Engine Position plug on the coil harness to the Main Engine harness connector labeled "Engine Position".
- ❑ 6.3 Cams Connect Cam Sensors located on the back of engine on each cylinder head. EXT always goes towards the exhaust manifold while INT always goes towards the intake manifold. (Fig. 3).
- ❑ 6.4 VCT Connect VCT Sensors located on the front of each bank. EXT always goes towards the exhaust manifold while INT always goes towards the intake manifold. (Fig. 4)
- ❑ 6.5 Crank (Required) Route Crank Sensor lead to right rear side of cylinder block and plug into Crank Sensor, located near bellhousing. (Fig. 3)
- ❑ 6.6 Coils (Required) Connect each coil in order according the the label on each connector.

## COIL LOCATIONS

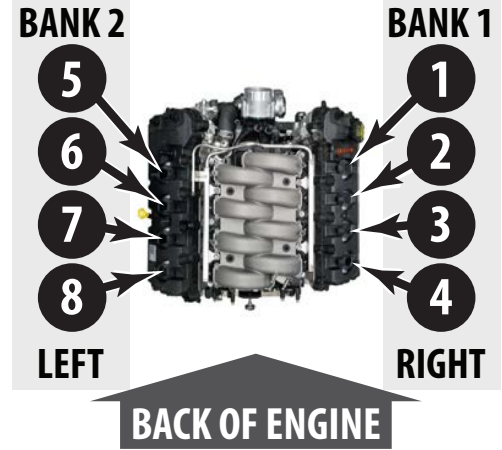

## INJECTOR LOCATIONS

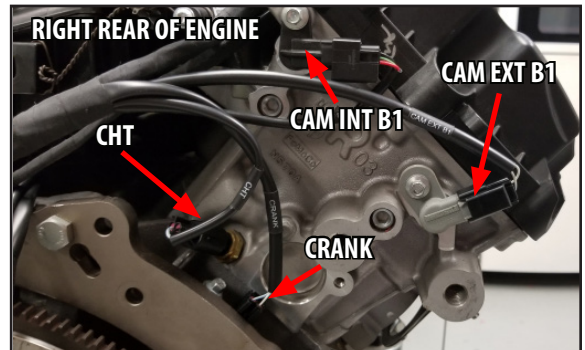
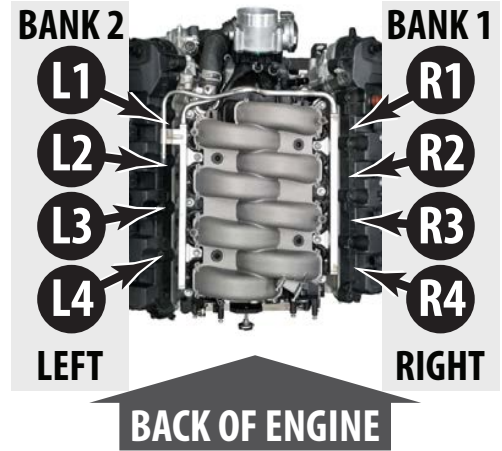

Fig. 3

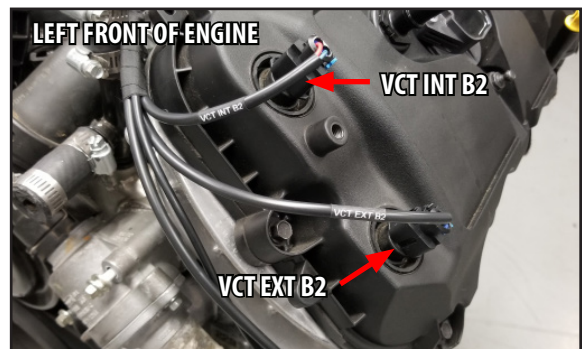

Fig. 4

## 7.0 Engine Sensor/Outputs Harness Routing and Installation

### Note:

- 7.1 Sensors/Outputs (Required) Connect Large Sensors/Outputs Harness connector to Main Engine Harness connector labeled Sens/Outs.
- 7.2 Map Sensor (Required) Connect vacuum line to MAP sensor. Mount sensor to the valve cover using the supplied nut and bolt as pictured.(Fig. 5)
- 7.3 Fuel Pressure (Optional) Connect Fuel Pressure Sensor Connector to Fuel Pressure Sensor located on the left side of the intake manifold.
- 7.4 Oil Pressure Route Oil Pressure Sensor connector behind the alternator located on the left side of engine. (Fig. 6)
- 7.5 CHT (Required) Cylinder Head Temp Sensor (Required) Route CHT Sensor Connector to CHT Sensor located on the right rear of the engine near the crank sensor. (Fig. 3)
- 7.6 ALT Alternator (Optional) Route Alt Connector to Alternator plug. (Fig. 6)
- 7.7 IAT Inlet Air Temp (Required) Route IAT Sensor Connector (Right Bank Harness) to Inlet Air Temp Sensor.

**Note:** Secure all Harnesses with included zip ties to prevent contact with hot or moving parts.

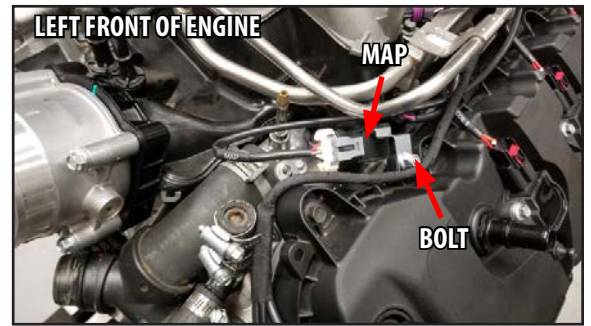

Fig. 5



Fig. 6

## 8.0 E TUNER 4 PLUS CALIBRATION WIZARD



The Tablet and ECU have been Bluetooth paired prior to shipping. No Bluetooth connection procedure should be necessary. If you are trying to pair an Android device, or are experiencing Bluetooth connectivity issues, refer to steps 8.5 and 8.6.





8.1 Power on the tablet by pressing and holding down the power button until the screen turns on. Power button configuration may vary on different Tablet configurations.

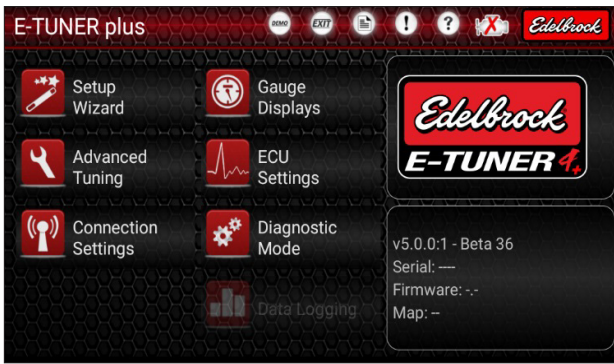

8.2 If the tablet isn't adequately charged, or isn't turning on, connect a USB charger to the Micro USB slot.

- Find the Edelbrock E-Tuner 4 Plus App Icon on the Home screen. Select the icon to launch the E-Tuner 4 Plus App.
- After completing each selection choose the Next Step Arrow  at the bottom of the page to proceed.
- For a more detailed explanation of any page in the E-Tuner Plus App, select the  help icon in the top bar of the displayed page.



8.3 Power up the Tablet and select the E Tuner 4 Plus App Icon  on your devices desktop. Attempt a Bluetooth connection with the ECU by touching the Red X on the Engine Icon (Connection Status) in the upper right corner of the page.



8.4 A Green check mark on the Connection Status Icon in the upper right corner indicates a Bluetooth connection. If a connection cannot be achieved, a red X will be present. If several attempts are unsuccessful, select Connection Settings from this page and follow step 8.5 for pairing a new device.

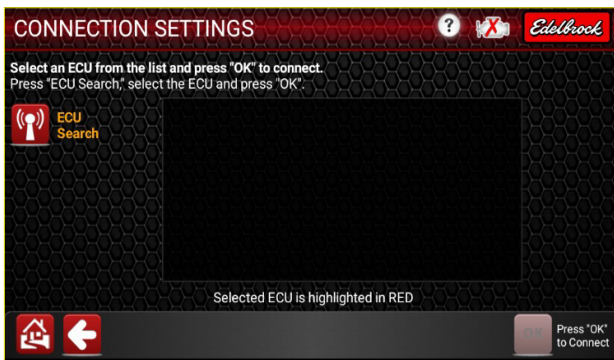

8.5 If already paired, skip to 8.7. Select the ECU Search Icon to search for an ECU Bluetooth Connection. The Red X on the Connection Status Icon will turn yellow with a rotating spiral indicating searching for a device.

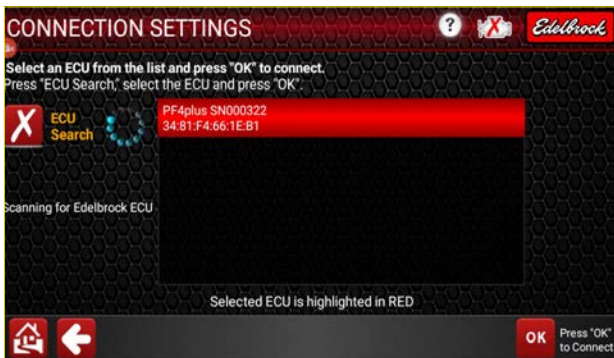

8.6 An ECU device will be displayed in the window. Numbers represent the ECU serial number. Select OK to start a Bluetooth connection with the selected device. When a connection is achieved, a Green Check will appear over the Connection Status Icon.

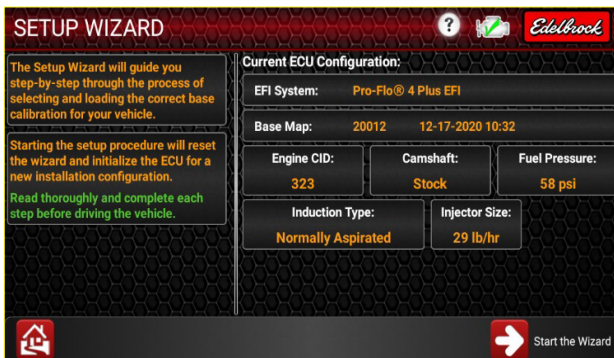

8.7 With a Bluetooth Connection achieved, select the Setup Wizard Icon from the E TUNER plus home page. Select the Arrow Icon in lower right corner of page to start the Wizard.

**MANUFACTURER** ? Edelbrock

Select the car manufacturer:

Chevrolet LS

Ford Coyote

Dodge Hemi

Next Step: Nr of O2 Sensors

8.8 Select the Ford Coyote.

**O2 SENSOR QUANTITY** ? Edelbrock

Select the amount of O2 sensors installed:

One O2 Sensor

Two O2 Sensors

Next Step: Engine Generation

8.9 Select how many O2 sensors are connected. It is required to run 1 sensor but 2 are optional.

**GENERATION** ? Edelbrock

Select the model generation:

Gen 1

Gen 2

Next Step: Pedal Type

8.10 Select your Engine Configuration.

- Gen 1 2011-2015.5
- Gen 2 2015.5-2017

**PEDAL TYPE** ? Edelbrock

Select the Pedal Type:

CR33-9F836-AB

Next Step: Throttle Body

8.11 Select your throttle pedal type. Only factory Ford Mustang pedal, or equivalent, are supported.

**THROTTLE BODY TYPE** ? Edelbrock

Select the Throttle Body type:

MY11-14 (BR3E-9F991-AB)

MY15-17 (FR3E-9F991-AA)

GT350 (GR3E-9F991-AA)

Next Step: Engine Displacement

8.12 Select Throttle Body type from the list of supported devices.

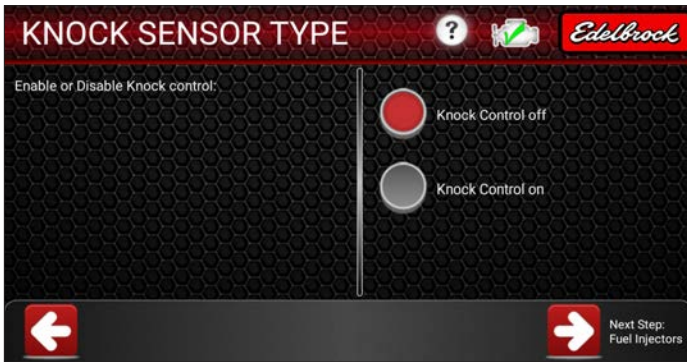

8.13 Enable or disable Knock Control Option. Requires auxiliary Knock Sensor Harness #36125

(Running a Knock Sensor is optional)

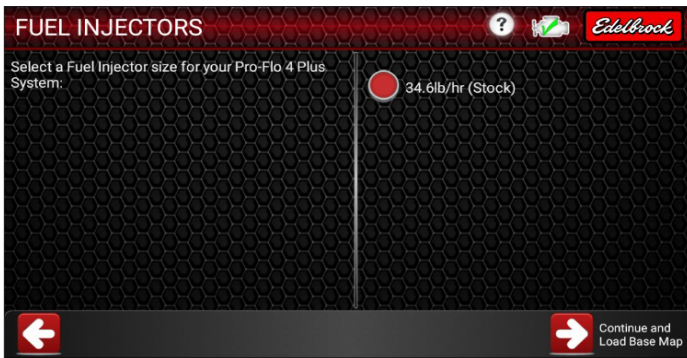

8.14 Select the injector size. Only factory Ford Coyote injectors are supported.

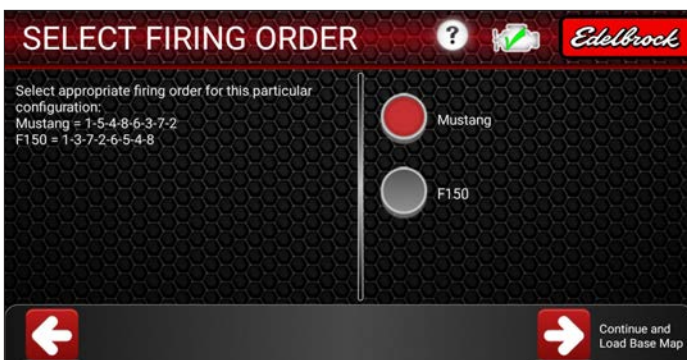

8.15 Select the firing order for your engine.

(Gen II applications only)

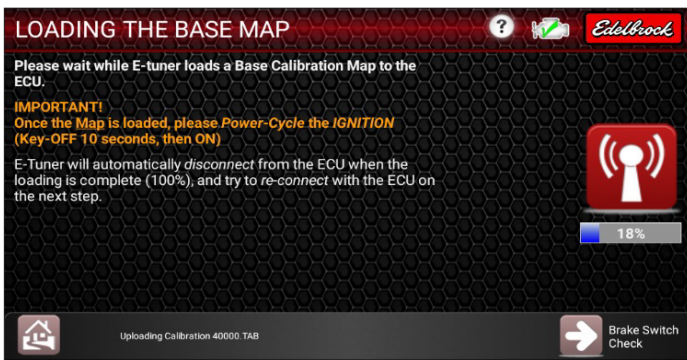

8.16 The calibration for your engine configuration is now uploading. This may take a few seconds.

When completed, cycle the key ON and OFF for 10 seconds, then select the arrow icon in the lower right corner to complete the final stages of the setup wizard.

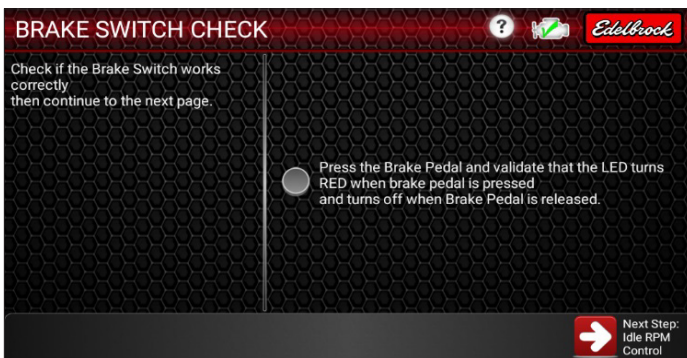

8.17 Perform a Brake Pedal Switch validation. This is necessary and functions as a safety feature in the DBW functionality. Edelbrock will not be responsible for accidental occurrences that may happen if this function is not properly operational.

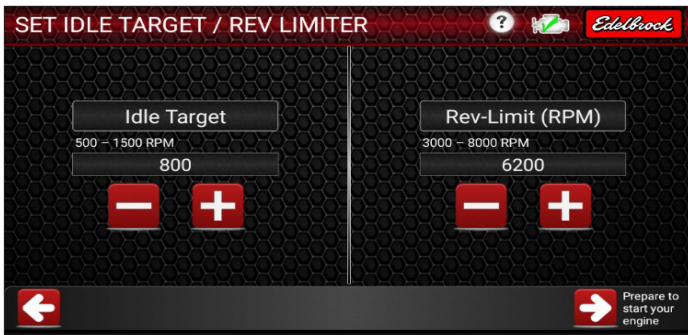

8.18 Set your desired Idle Target and Rev Limit values.

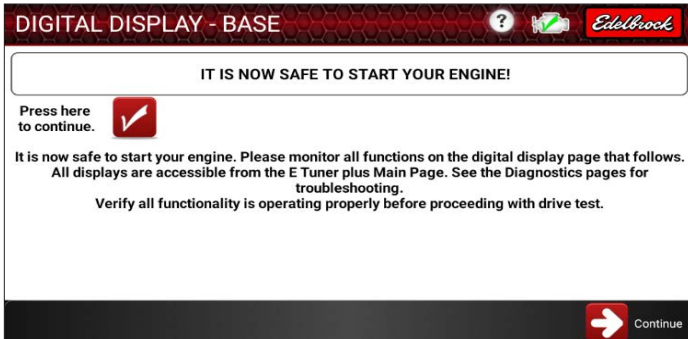

8.19 Setup is now complete. Before starting engine, verify the following items:

- Has the battery been reconnected?
- Does the DBW throttle body and pedal operate correctly?
- Are all wiring harness connectors connected?
- Has the supplemental fuel system been installed?
- Has the fuel system been checked for leaks?
- Is the gas tank filled with unleaded fuel and full?
- Has the exhaust system been checked for leaks?
- Is the O2 sensor installed and connected?
- Have resistor type spark plugs been installed?
- Is the Android device fully charged?

**If all Sensor readings look acceptable, you can proceed with starting your engine.**



8.20 Digital Display Page is provided to monitor major functions of EFI system.

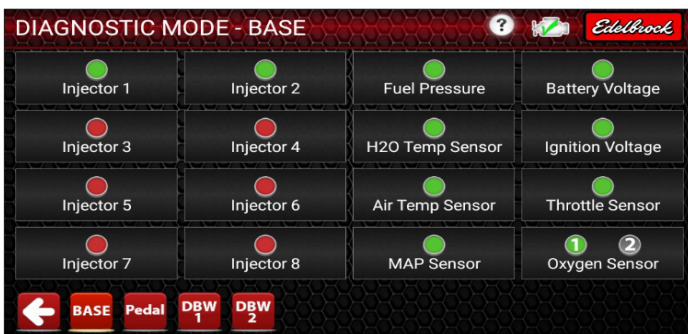

8.21 Diagnostic mode is provided to monitor sensor functionality and assist in troubleshooting. This may be accessed from the main E Tuner Plus page.



8.22 From the E Tuner Plus Main Page, become familiar with system options, tuning aids, and functionality. The window in lower right provides current Calibration and Firmware definition information.



## 9.0 DIGITAL DISPLAY

9.0 It is important to verify that all functions of the EFI system are operating properly. Turn the key ON, Open the E Tuner 4 Plus APP, and verify a Bluetooth Connection. From the E Tuner Plus main menu select Gauge Display.

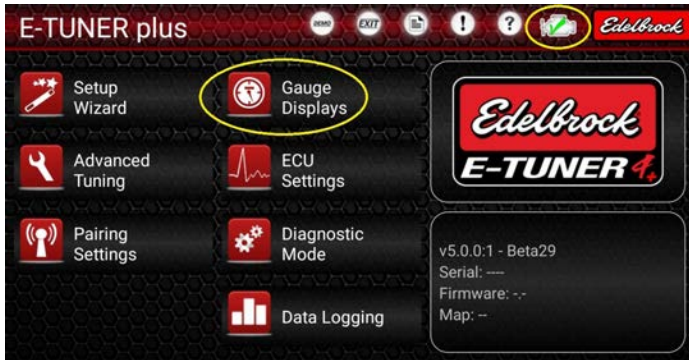

9.1 From the Main Page, select Gauge Displays.

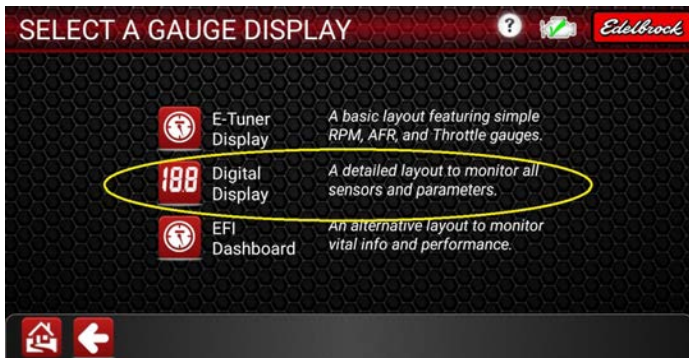

9.2 Select Digital Display in the menu.



9.3 The Digital Display Page is a useful tool for observing all functions of the Engine.

### **BASIC DIGITAL DISPLAY NOTES:**

- » Fuel Pressure should read 58-60 psi while pump is running. Pump runs for 8 seconds after key on then shuts off. Pump restarts during cranking and run.
- » AFR1 and AFR2 will begin reading approximately 20 seconds after engine starts, allowing sufficient time for O2 Sensors to warm up.
- » Short FT1 and Short FT2 are the Closed Loop Fuel corrections for each O2 Sensor. These should adjust and indicators should illuminate green when AFR1 and AFR2 start function.
- » Long FT1 and Long FT2 are the Long-Term Fuel Correction applied to the main fuel map. These will start functioning once the Coolant Temperature has exceeded 165F degrees
- » **O2 Function Note: Only AFR1 and FT1 function if running single O2 Sensor input.**
- » Idle Target will decay to final target value after engine reaches 165 degrees.
- » If a DBW related fault is present, the Pedal and or Throttle Indicators will illuminate Red.

## **10.0 GETTING FAMILIAR WITH PRO FLO 4 PLUS / E TUNER PLUS**

After the setup wizard has been completed, the idle speed has been set and all system functions verified the use of the tablet is no longer required to operate the Pro Flo 4 Plus EFI system. The tablet is only necessary to monitor system performance using the Tuning Gauge Displays and to make any desired modifications to the calibration. All modifications made with the tablet after the completion of the Setup Wizard will require blue tooth connectivity with the Pro Flow 4 Plus ECU and will be applied in real time. A green check on the engine icon in the upper right corner of the screen indicates a connection with the ECU.

Review and become familiar with the Advance Tuning functions in the App. The provided calibration for your application should function acceptably. The advance tuning functions have been provided to find tune your engines performance if necessary. For assistance with any page in the App, click the small (?) In the upper right corner for further explanation of the provided functions.

The Pro Flo 4 Plus will constantly modify and apply fuel corrections to optimize your vehicle's performance. Depending on your driving style and frequency of operation, this process will require adequate time to learn and adjust for inaccuracies during light acceleration, cruise, and wide-open throttle conditions.

During the Self Learning process, the Pro Flow 4 Plus system will continually save fuel trim modifications and store them to the ECUs memory automatically. Fuel Trim modifications and set up information will be stored in the ECU until deleted or erased by the user. Power failures and loss of connectivity will not erase any stored data in the ECU.

The key to driving your vehicle initially with the Pro Flo 4 Plus EFI is to employ slow smooth throttle transitions and acceleration. Try to drive the vehicle in a manner that employs all conditions; light load, heavy load, high RPM and low RPM.

If you experience a situation where the engine is not performing properly, it helps to observe the (Short FT) Fuel Trims. The Digital Display screen is most useful for these observations. Try to hold a steady RPM and Vacuum level at the point that the vehicle is struggling, as the Pro Flo 4 Plus system makes adjustments, the Short FT Fuel Corrections should start to decrease and the Long FT corrections should adjust accordingly. AFR and AFR SP should become aligned.

The Pro-Flo 4 Plus is programmed with cold start tables. These tables function like a choke system on a carburetor. The idle RPM will raise during initial cold start conditions, then decay out to the desired idle speed set point as the water temperature increases to 165 degrees F.

The fuel pump is programmed to run 5 seconds during key ON then shuts off automatically until cranking is sensed. Bluetooth connection remains 45 seconds post key "OFF".

### **PRO FLO 4 EFI COYOTE SETUP WIZARD MAP MATRIX**

**NOTE:** The calibration I.D. is chosen automatically during the Setup Wizard procedure. The Calibration I.D. will be located on the home screen in the bottom right window after "MAP". Be sure your setup matches the calibration.

<b>CAL. I.D</b>	<b>ENGINE</b>	<b>DISPLACEMENT LITERS</b>	<b>DISPLACEMENT CUBIC INCHES</b>	<b>INJECTOR LbHr</b>	<b>INJECTOR PART#</b>	<b>CATEGORY</b>	<b>CAM DURATION @ .050 LIFT</b>
30000	2011-14 Gen I Ford Coyote	5.0L	302-320	34.6	02080158227	Stock	210 or less
30100	2015-17 Gen II Ford Coyote	5.0L	302-320	34.6	02080158227	Stock	210 or less

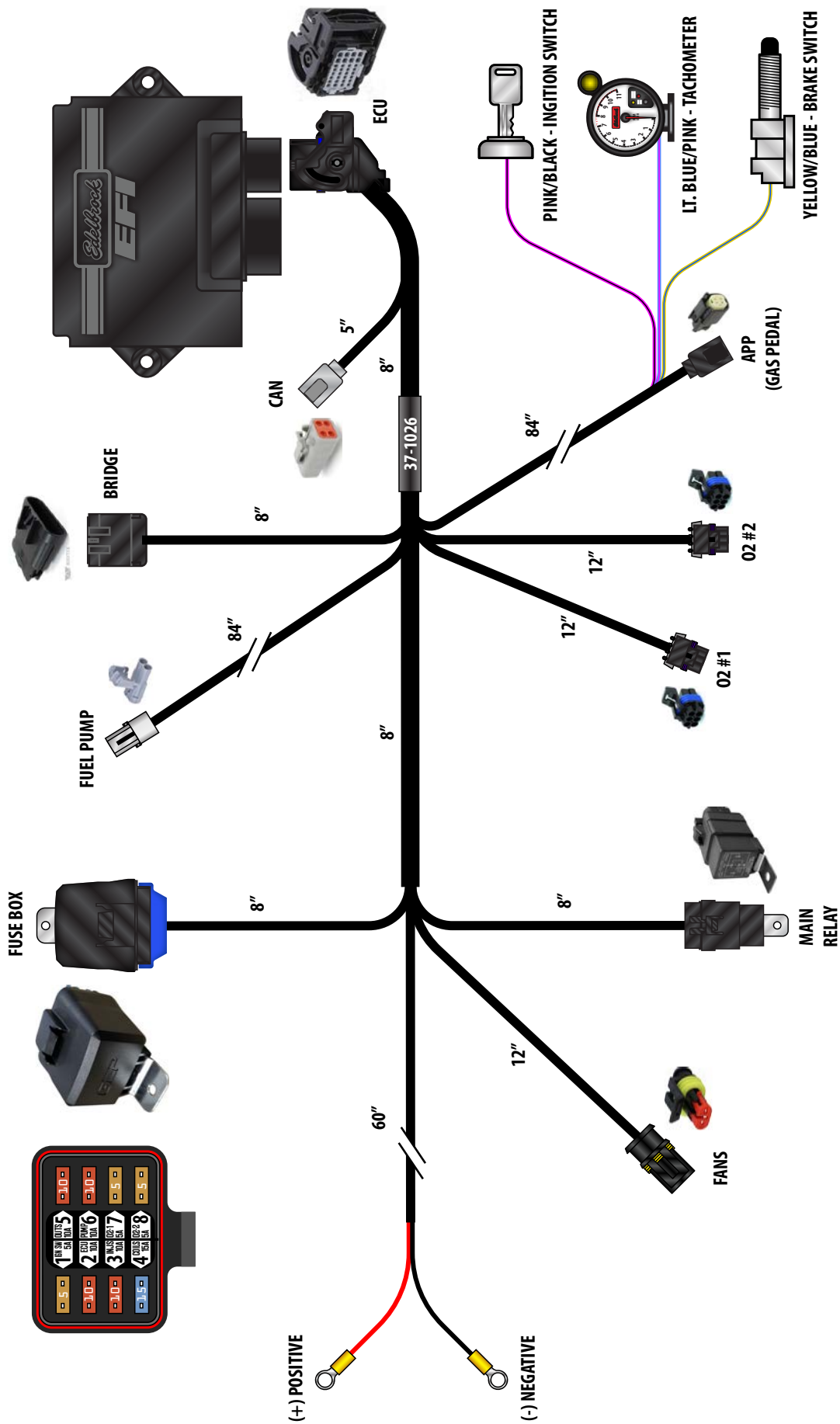

**EDELROCK PRO-FLO 4 PLUS  
CHASSIS HARNESS  
PART# 37-1026**

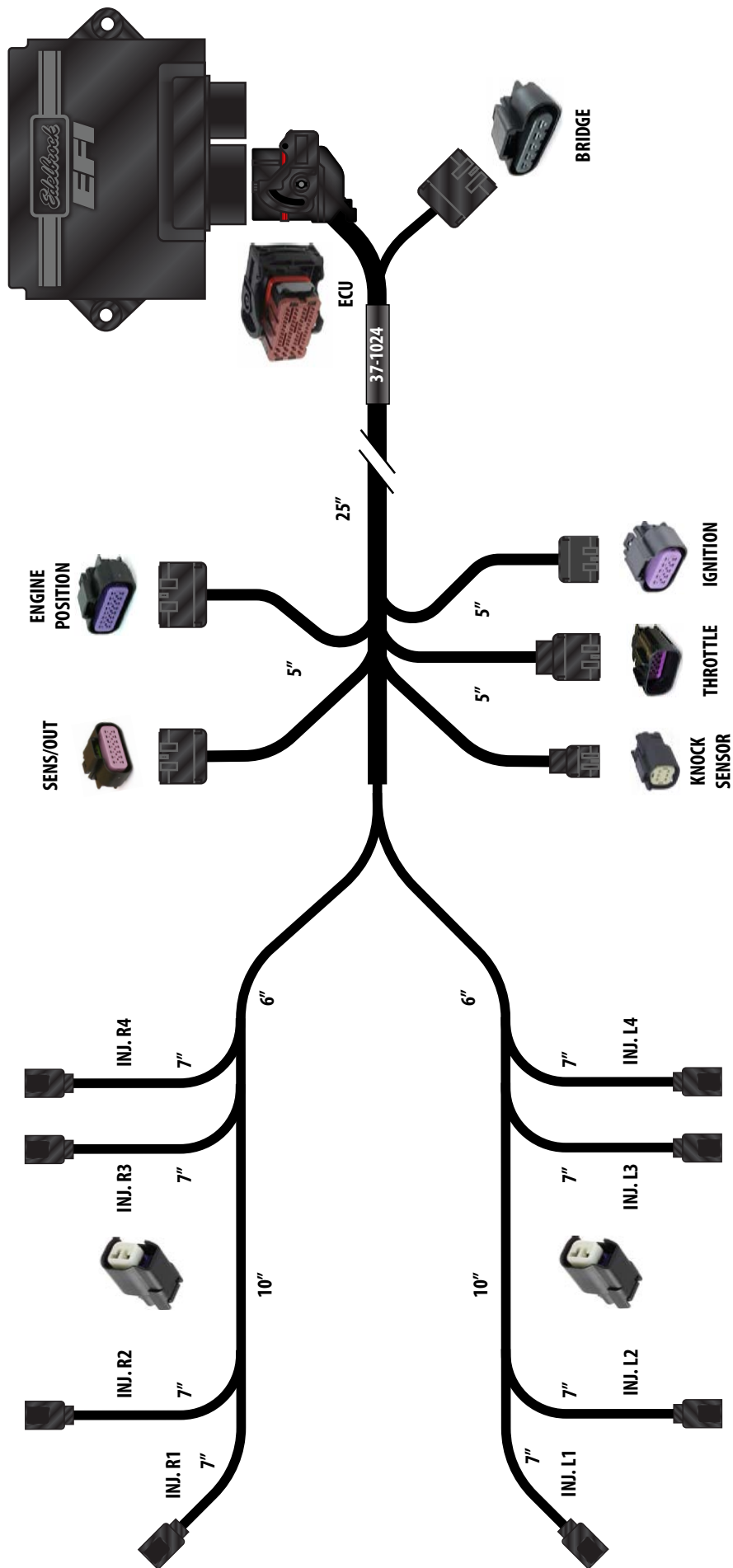

**EDELBRICK PRO-FLO 4 PLUS  
MAIN ENGINE HARNESS  
PART# 37-1024**

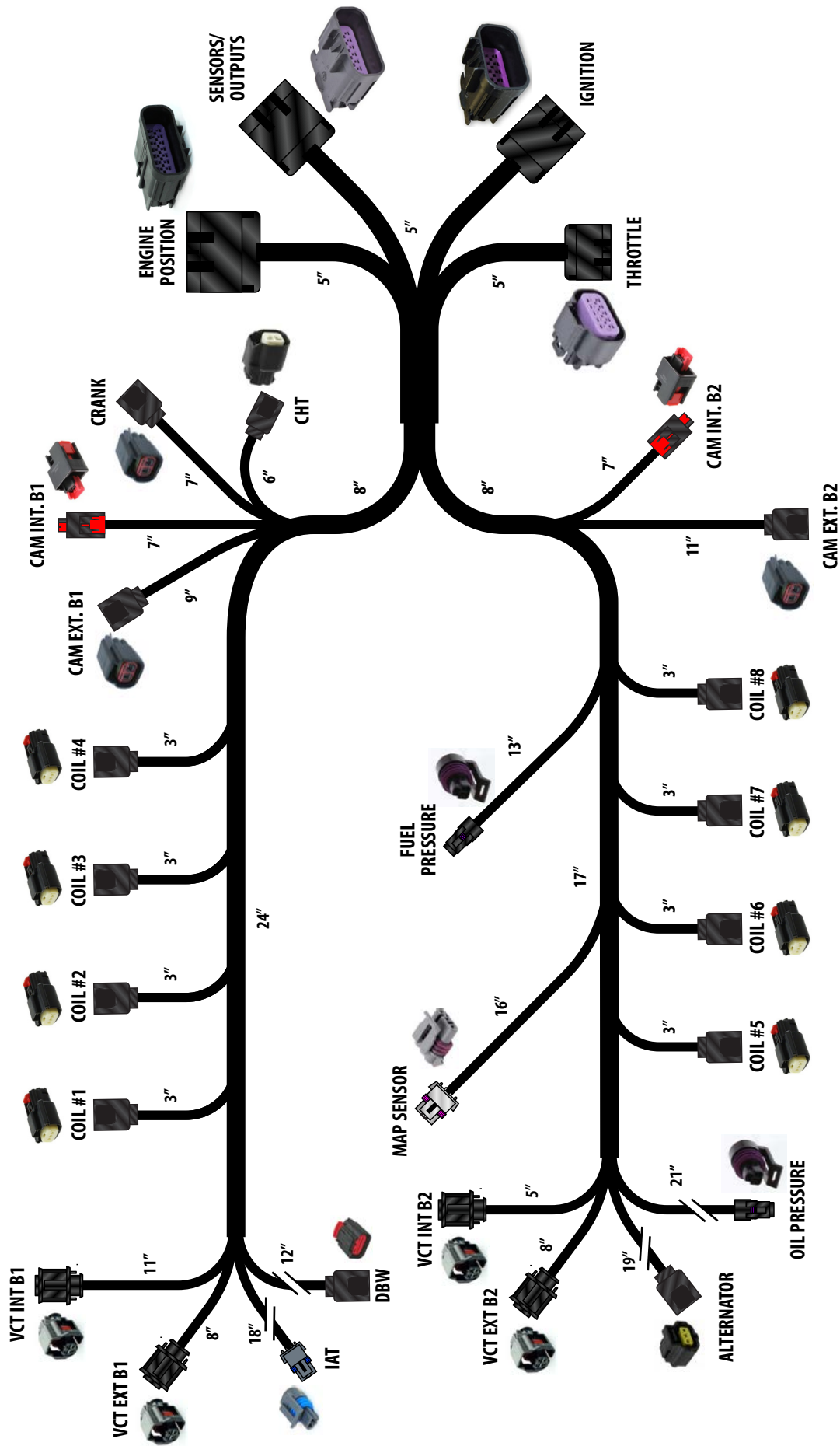

**EDELbrock PRO-FLO 4 PLUS**  
**2011-15 COYOTE SUB-ENGINE HARNESS**  
**PART# 37-1025**

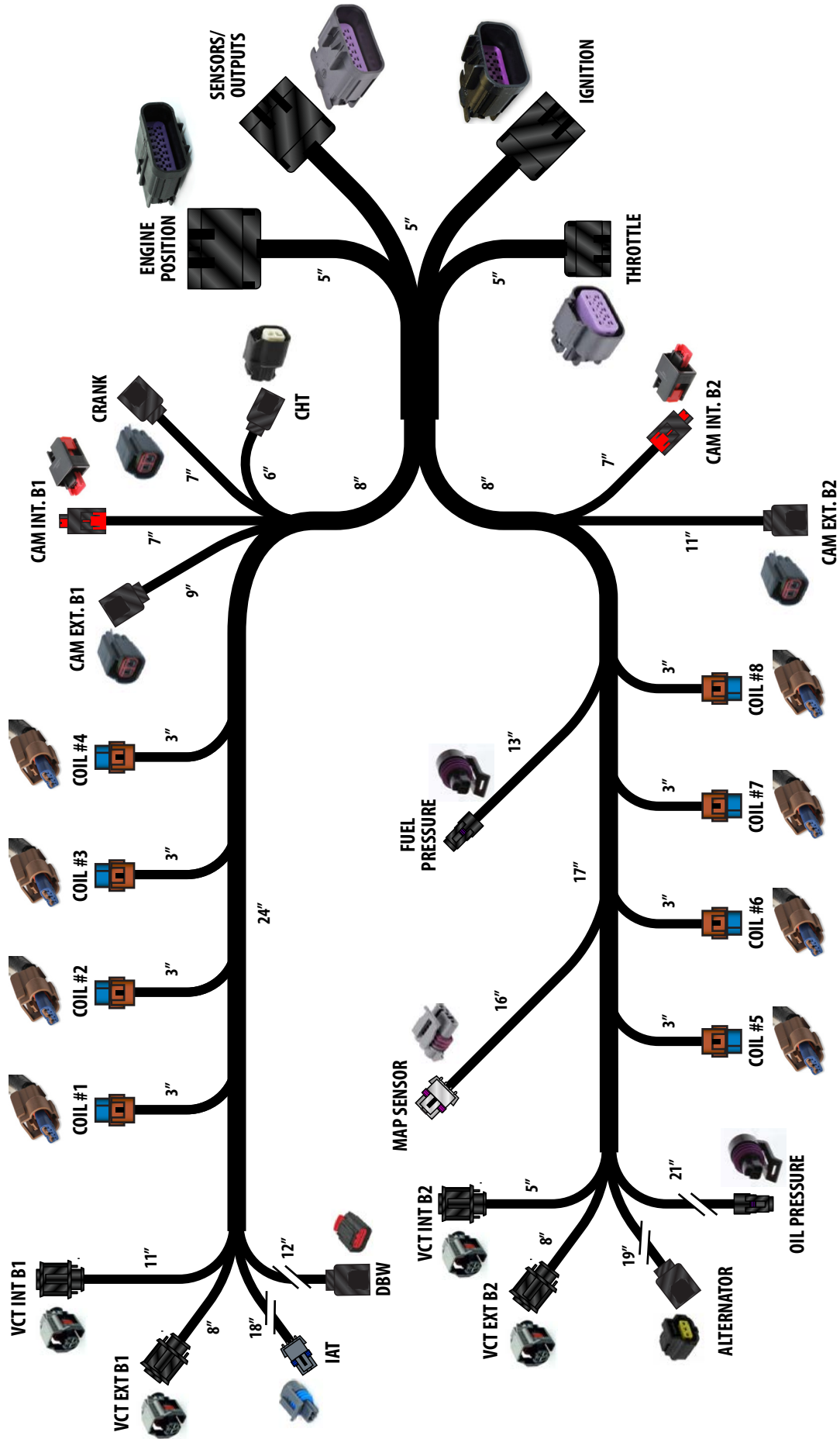

**EDELbrock PRO-FLO 4 PLUS  
2015-17 COYOTE ENGINE HARNESS  
PART# 37-1022**

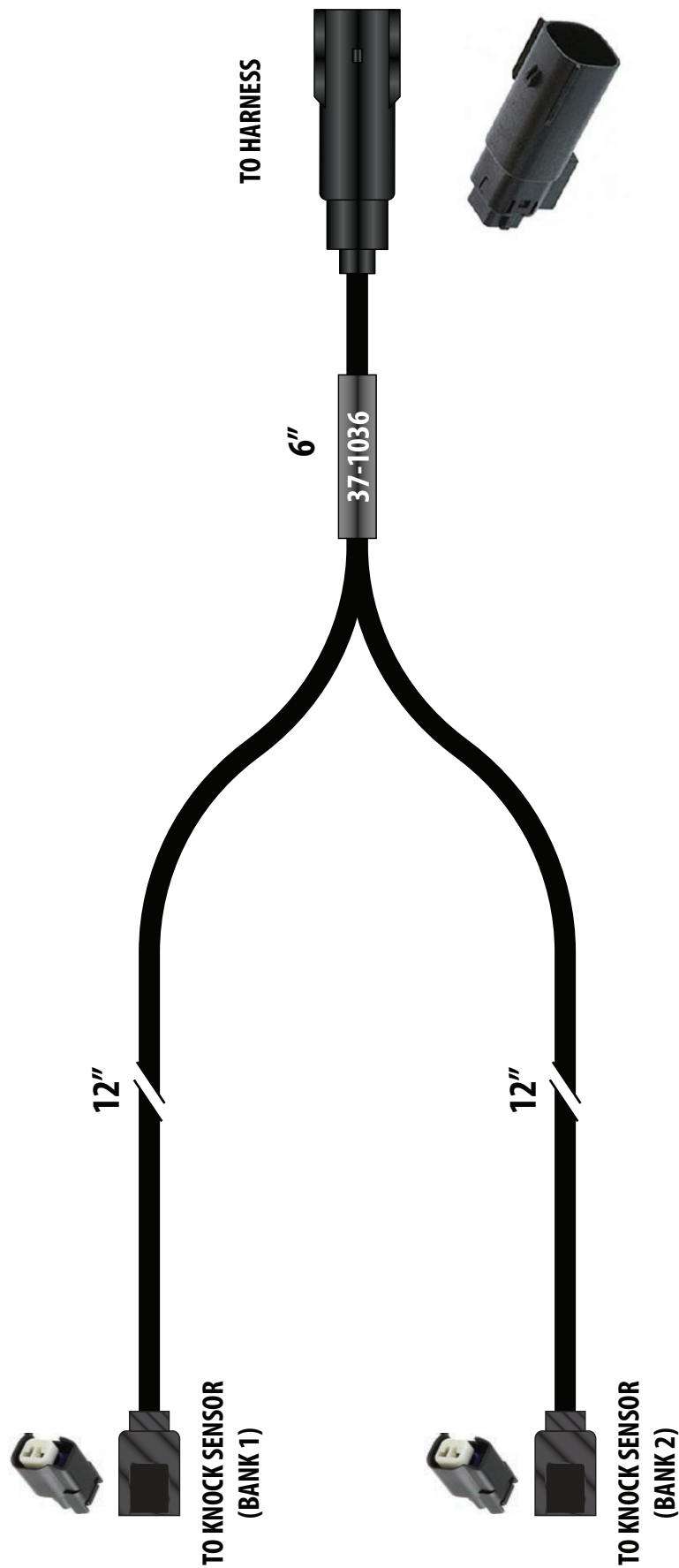

**EDELBROCK PRO-FLO 4 PLUS  
OXYGEN SENSOR EXTENSION (Optional, not included)  
PART# 37-1036**

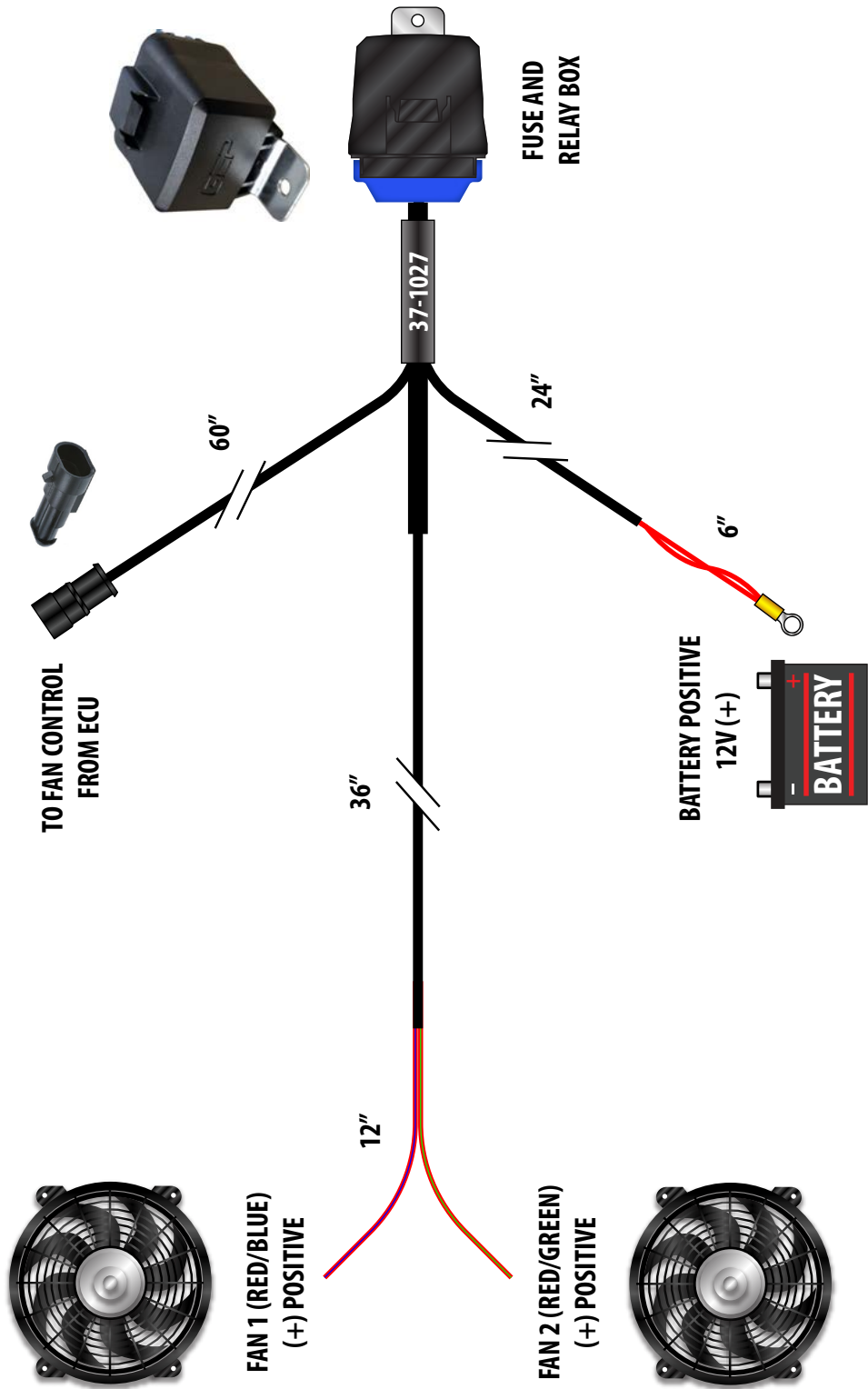

**EDELBROCK PRO-FLO 4 PLUS  
FAN RELAY HARNESS  
PART# 36115 (Sold separately)**



## **WARRANTY**

Edelbrock warrants the Edelbrock Pro-Flo 4 Plus EFI system to be free from defects in both workmanship and materials for a period of two year from date of purchase, provided that the product is properly installed and subjected to normal use and service, is not used for racing or competition purposes and that the product is not modified or altered in any way unless specified by our instructions. Our warranty service and repair facility is located at 2700 California Street, Torrance, CA 90503. Customers requiring warranty assistance should contact the dealer from whom they purchased the product. In turn, the dealer will contact Edelbrock, and we will determine the method of satisfying the warranty. Should Edelbrock determine that the product needs to be returned to the factory, it should be accompanied by proof of purchase and a clear description of the exact problem. The product must be returned freight pre-paid. If a thorough inspection of the product by the factory indicates defects in workmanship or material, our sole obligation shall be to repair or replace the product. This warranty covers only the product itself and not the cost of installation or removal.

**EDELBROCK LLC SHALL NOT BE LIABLE FOR ANY AND ALL CONSEQUENTIAL DAMAGES OCCASIONED BY THE BREACH OF ANY WRITTEN OR IMPLIED WARRANTY PERTAINING TO THIS SALE, IN EXCESS OF THE PURCHASE PRICE OF THE PRODUCT SOLD.**

If you have any questions regarding this product or installation, please contact our Technical Department from 7:00 am - 5:00 pm, Pacific Standard Time, Monday through Friday at: 800-416-8628.



**Edelbrock LLC • 2700 California St. • Torrance, CA 90503  
Tech-Line: 800-416-8628**

0	0	0	0	0	0	0	0	0	0	0	0	0	0	0	0	0	0	
3	4	4	4	4	4	4	4	6	6	6	6.5	7	7	1	2	3	4	
9	10	11	11	11	11	11	11	11	12	13	13.5	14	14	7	8	9	10	
10	11	12	12	12	12	12	12	13	14	15	15.5	16	16	8	9	10	11	
11	12	13	13	13	13	13	14	15	16	17	17.5	18	18	9	10	11	12	
12	13	14	14	14	14	14	14	16	17	18	18.5	19	19	10	11	12	13	
13	14	14	14	14	14	14	15	17	18	19	19.5	20	20	11	12	13	14	
14	14	14	14	14	15	16	18	19	20	20.5	21	21	21	12	13	14	14	
15	15	15	15	16	17	18	20	21	22	22.5	23	23	23	13	14	15	15	
15	16	17	17	18	19	20	21	22	22	23.5	24	24	24	14	15	15	16	
17	19	22	25	27	29	29	29	29	30	30	30	30	30	17	17	17	19	
17	19	23	25	28	29	30	31	31	32	32	32	32	32	17	17	17	19	
17	19	24	26	29	30	31	32	33	33	34	34	34	34	17	17	17	19	
17	19	25	28	30	31	32	33	34	35	35	36	36	36	17	0	0	0	
0	0	0	0	0	0	0	0	0	1	2	3	3.5	4	4	0	0	0	
0	0	0	0	0	0	0	0	1	3	4	5	5.5	6	6	1	2	3	
2	3	4	4	4	4	4	4	4	6	6	6	6.5	7	7	7	8	9	
8	9	10	11	11	11	11	11	11	11	12	13	13.5	14	14	8	9	10	
9	10	11	12	12	12	12	12	12	13	14	15	15.5	16	16	9	10	11	
10	11	12	13	13	13	13	13	14	15	16	17	17.5	18	18	10	11	12	
11	12	13	14	14	14	14	14	14	16	17	18	18.5	19	19	11	12	13	
12	13	14	14	14	14	14	14	15	17	18	19	19.5	20	20	12	13	14	
13	14	14	14	14	14	14	15	16	18	19	20	20.5	21	21	13	14	15	
14	15	15	15	15	16	17	18	20	21	22	22.5	23	23	14	15	15	15	
15	15	16	16	17	17	18	19	20	21	22	22	23.5	24	24	17	17	17	
17	17	19	22	25	27	29	29	29	29	30	30	30	30	30	17	17	17	
17	17	19	23	25	28	29	30	31	31	32	32	32	32	32	17	17	17	
17	17	19	24	26	29	30	31	32	33	33	34	34	34	34	17	17	17	
17	17	19	25	28	30	31	32	33	34	35	35	36	36	36	17	17	17	
17	17	19	25	28	30	31	32	33	34	35	35	36	0	0	0	0	0	
0	0	0	0	0	0	0	1	2	3	3.5	4	4	4	0	0	0	0	
0	0	0	0	0	0	1	3	4	5	5.5	6	6	6	1	2	3	4	
4	4	4	4	4	4	4	6	6	6	6.5	7	7	7	7	8	9	10	
10	11	11	11	11	11	11	11	12	13	13.5	14	14	8	9	10	11	12	
11	12	12	12	12	12	12	13	14	15	15.5	16	16	9	10	11	12	13	
12	13	13	13	13	13	14	15	16	17	17.5	18	18	10	11	12	13	14	
13	14	14	14	14	14	14	16	17	18	18.5	19	19	11	12	13	14	14	
14	14	14	14	14	15	17	18	19	19.5	20	20	20	12	13	14	14	14	
14	14	14	14	15	16	18	19	20	20.5	21	21	21	13	14	15	15	15	
15	15	15	16	17	18	20	21	22	22.5	23	23	23	14	15	15	16	16	
16	16	17	17	18	19	20	21	22	22	23.5	24	24	17	17	17	19	22	
19	22	25	27	29	29	29	29	30	30	30	30	30	17	17	17	19	23	
19	23	25	28	29	30	31	31	32	32	32	32	32	17	17	17	19	24	
19	24	26	29										34	17	17	17	19	25
19	25	28	30										36	17	17	17	19	25
0	0	0											3.5	4	4	0	0	0
0	0	0											5.5	6	6	0	0	0
2	3	4	4										6.5	7	7	1	2	3
8	9	10	11										13.5	14	14	7	8	9
9	10	11	12										15.5	16	16	8	9	10
10	11	12	13	13	13	13	13	14	15	16	17	17	17.5	18	18	9	10	11
12	13	14	14	14	14	14	14	15	16	17	18	18	18.5	19	19	10	11	11



**Edelbrock. LLC**  
**2700 California St, Torrance, CA 90503**  
**www.edelbrock.com**